

Royal Vendors, Inc.

# RVV Gen II

RVV Generation II with Five-Button Programming  
Operation and Service Manual

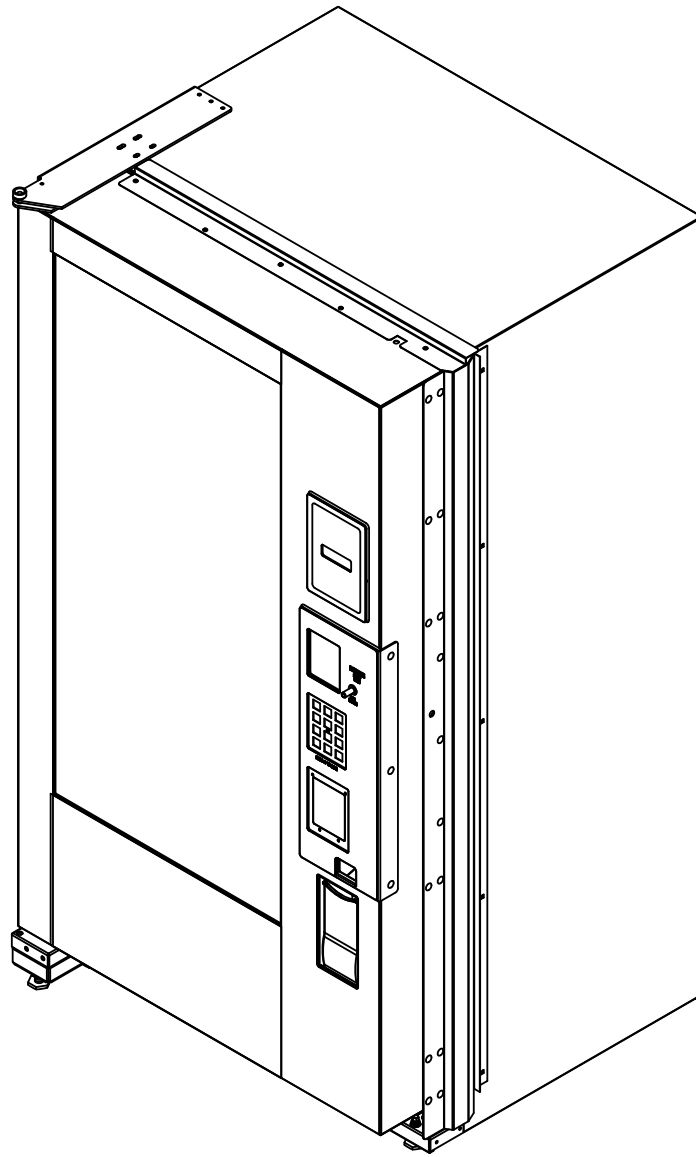

Manufactured by



Royal Vendors, Inc. • 426 Industrial Boulevard • Kearneysville WV 25430-2776 • USA  
Telephone +1 304 728 8363 • Fax +1 304 725 4016 • [technicalinquiry@royalvendors.com](mailto:technicalinquiry@royalvendors.com) • [parts@royalvendors.com](mailto:parts@royalvendors.com) • [www.royalvendors.com](http://www.royalvendors.com)



**Royal Vendors, Inc. • 426 Industrial Boulevard • Kearneysville WV 25430-2776 • USA**  
Customer Service: +1 (304) 728-8363 or Toll Free 1 (800) 931-9214 • Fax +1 (304) 725-4016

**E-mail:** [technicalinquiry@royalvendors.com](mailto:technicalinquiry@royalvendors.com)  
[parts@royalvendors.com](mailto:parts@royalvendors.com)

**Website:** [www.royalvendors.com](http://www.royalvendors.com)

# TABLE OF CONTENTS

---

<b>SAFETY SEGMENT .....</b>	<b>5</b>
<b>SECTION 1: General Information and Setup .....</b>	<b>7</b>
Introduction.....	7
Unpacking the Vender and Installing It On Location .....	7
Voltage Requirements and Vender's Power Cord .....	8
Programming the Vender .....	8
Loading the Vender .....	8
Specifications .....	9
Important Note on Transporting the RVV NG .....	9
Vender Identification .....	9
<b>SECTION 2: Vender Component Explanation .....</b>	<b>10</b>
Vender Main Controller (including pinouts) .....	10
Delivery Mechanism Controller.....	13
Touch Pad .....	14
Delivery Sensor .....	14
Door Switches .....	14
Vacuum Fluorescent Display (VFD) .....	14
Electronic Power Supply .....	14
Refrigeration System .....	15
Ballast.....	17
Credit Peripherals.....	17
TriTeq Electronic Door Lock .....	18
<b>SECTION 3: Vender Programming .....</b>	<b>19</b>
Internal (Service) Menu .....	20
Cash Counters .....	20
Sales Counters.....	20
Card Counters .....	20
Token Counters .....	20
Free Vend Accounting .....	20
Error Codes .....	21
Test Modes .....	23
Set Prices .....	26
Space to Sales .....	26
Set Package Size ( <i>software revisions 2.15 and after only</i> ) .....	27
Configurations .....	28
Revert to Defaults.....	29
Exact Change Only .....	29
Coin Pay Out .....	29
Tube / Stack Fill.....	30
Recycler Pay Out .....	30
Set Discounts .....	30
Selection Blocking 1 / 2 / 3 .....	32
Set Time / Date.....	33
Refrigeration .....	34
Lighting Control .....	36

# TABLE OF CONTENTS (continued)

---

Preview Password .....	37
Set Language .....	37
Manual Over Rides .....	37
Return to Sales.....	38
External Menu .....	39
Sales Counters .....	39
Error Codes .....	39
Return to Sales.....	39
<b>SECTION 4: Vender Maintenance .....</b>	<b>40</b>
What to Clean.....	40
Lubrication .....	40
Preventive Maintenance .....	40
RVV NG Product Cup Manual Calibration.....	41
<b>SECTION 5: Troubleshooting .....</b>	<b>42</b>
Troubleshooting by Error Codes.....	42
Troubleshooting by Symptom.....	45
Test Diagnostics Routines Troubleshooting .....	48
<b>SECTION 6: Parts Catalog .....</b>	<b>64</b>
<b>Programming Flowchart .....</b>	<b>91</b>
<b>RVV NG Wiring Schematic.....</b>	<b>92</b>
<b>CREDIT AND REPLACEMENT POLICY.....</b>	<b>Back Cover</b>

# SAFETY SEGMENT

---

## ROYAL VENDORS' COMMITMENT TO SAFETY

Royal Vendors is committed to safety with all of our product designs. We are committed to notifying the user of a possible danger involving the improper handling or maintenance of our venders. The servicing of any electrical or mechanical device involves **potential dangers**, both to those servicing the equipment and to users of the equipment. These dangers can occur because of improper maintenance or usage. The purpose of this safety segment is to alert everyone servicing Royal equipment of potentially dangerous areas, and to provide **basic safety guidelines** for proper upkeep.

The service manual contains various **warnings** that should be carefully read to minimize the risk of personal injury. This manual also contains service information to ensure that proper methods are followed to avoid damaging the vender or making it unsafe. It is also important to understand these **warnings** provide general guidance only. Royal could not possibly know, evaluate, or advise of all of the conceivable ways in which service might be done. Consequently, Royal cannot predict all of the possible dangerous results. These outlined safety precautions are the basis for an effective safety program. Use these safety measures, along with the service bulletins, helpful hints and product specification sheets, when installing or servicing Royal equipment.

We recommend that persons servicing our equipment maintain a similar commitment to safety. **Only personnel properly trained should have access to the interior of the vender.** This will minimize the potential dangers that are inherent in electrical and mechanical devices. Royal has no control over the vender once it leaves the premises. It is the owner or lessor's responsibility to maintain the vender in a safe condition. See installation insert located in the coin box of a new vender for proper installation procedures and refer to the service manual for recommended maintenance procedures. If you have any questions, please contact the Technical Services Department at 1.800.931.9214.

## SAFETY REGULATIONS

- Read the safety segment before installation or service.
- Test for proper grounding before installing to reduce the risk of electrical shock and fire.
- Turn off or disconnect power cord from wall outlet before servicing.
- Only fully trained service technicians should service vender when vender has power.
- Remove any product before moving a vender.
- Use appropriate equipment when moving a vender.
- Always wear eye protection, and protect your hands, face, and body when working near the refrigeration system.
- Use only authorized replacement parts.
- Be aware of inherent dangers in rocking or tipping a vender.

## SECTION I: ELECTRICAL HAZARDS GENERAL ADVICE

Careless or improper handling of electrical circuits can result in injury or death. Anyone installing, repairing, loading, opening, or otherwise servicing a vender should be aware of this precaution. Apply all of the normal precautions when handling electrical circuits, such as:

- Refrigeration servicing to be performed by qualified personnel only.
- Unplug the vender before servicing.
- Replace electrical cords if there is any evidence of fraying or other damage.
- Keep all protective covers and ground wires in place.
- Plug equipment into outlets that are properly grounded and polarized (where applicable), and protected with fuses or circuit breakers of the correct size.
- All electrical connections must be dry and free of moisture before applying power.

**WARNING:**  
**ALWAYS TEST TO VERIFY PROPER GROUNDING PRIOR TO INSTALLATION IN ORDER TO REDUCE THE RISK OF ELECTRICAL SHOCK AND FIRE.**

# SAFETY SEGMENT

---

## SECTION II: ELECTRICAL HAZARDS

### A. Servicing with “Power Off”

For maximum safety, unplug the power cord from the wall outlet before opening the vender door. This will remove power from the equipment and avoid electrical hazards. Service personnel should remain aware of possible hazards from hot components although electrical power is off.

### B. Servicing with “Power On”

Some service situations may require access with power on. Only fully qualified service technicians should perform power-on servicing. Particular caution is required in servicing assemblies that combine electrical power and mechanical movement. Sudden movement (to escape mechanical action) can result in contact with live circuits and vice versa. It is therefore important to maintain maximum clearances from both moving parts and live circuits when servicing.

### WARNINGS:

- 1. ONLY FULLY TRAINED PERSONNEL SHOULD ACCOMPLISH “POWER-ON” SERVICING. SUCH SERVICE BY UNQUALIFIED INDIVIDUALS CAN BE DANGEROUS.**
2. LIGHTING CIRCUITS CAN BE HAZARDOUS. ALWAYS DISCONNECT VENDER FROM THE WALL OUTLET BEFORE REPLACING A BULB OR SERVICING THE VENDER IN THAT AREA.
3. NEVER USE A HOSE, PRESSURE WASHER OR ANY CLEANING METHOD THAT COULD WET ELECTRICAL COMPONENTS. SEE CLEANING SECTION OF MANUAL FOR SUGGESTED CLEANING METHODS. IF WATER CONTAMINATION OF ELECTRICAL COMPONENTS IS SUSPECTED, USE QUALIFIED ELECTRICAL TESTING EQUIPMENT AND TEST METHODS TO ASSURE THAT VENDER IS NOT A HAZARD BEFORE APPLYING POWER FOR ANY REASON.

## SPECIAL NOTE FOR VENDERS EMPLOYING R744 (Carbon Dioxide) REFRIGERATION UNITS

1. The vender must be installed in a well-ventilated area. Installation in confined spaces must be avoided.
2. Users and / or installers must follow requirements in the R744 Material Safety Data Sheet (MSDS) and in the Safety Standard for Refrigeration Systems, ANSI / ASHRAE 15.

# SECTION 1: General Information and Setup



## VISION VENDER Generation II

# General Information

## Introduction

This manual contains installation, operation, and service instructions for the Royal Vision Vender NG (RVV NG), by Royal Vendors, Inc. This manual also contains a parts catalog and electrical schematic for the RVV NG.

The RVV is a microprocessor-controlled glass-front vender that permits pricing per selection from \$0.00 to \$99.95. The RVV provides electronic space-to-sales programmability, and it will collect, store, and transfer MIS data fields to a hand-held computer (HHC) or on-line device through a DEX port.

## Unpacking the Vender and Installing It On Location

### UNWRAP THE VENDER

Unwrap the vender and remove the padding. Check for any signs of damage. If the vender is damaged, contact the carrier immediately. They will instruct you on the procedure for filing a claim.

*If the vender is being stored, remove the plastic stretch wrap, cardboard cover, and styrofoam cushioning first. The plastic stretch wrap and styrofoam cushioning can adhere to the exterior of the vender over an extended period of time, damaging the vender's finish.*

**Note:** For venders with T-handle locks, the vender's keys are located in the coin cup.

### REMOVE THE SHIPPING SKID

Separate (split) each section of the shipping skid by inserting a claw hammer, crowbar, or similar device into the slot of each section to break it apart. Tilt the vender slightly to remove the separated pieces. (See Figure 1.1.)

### REMOVE DOOR BLOCK

After opening the vender's door, locate the wooden shipping block at the bottom right under the door. Lift the block straight up to remove it.

### REMOVE THE INTERIOR PACKING

Before plugging in the vender's power cord, remove the interior packing. Failure to remove this packing before plugging in the vender could result in damage to the vend mechanisms.

- Remove the packing tape which secures the case supports.
- Remove the binder clips that secure each of the two belts, located approximately in the middle of the belts' runs.

### PLACING THE VENDER ON LOCATION

When placing the vender on location, allow for a minimum of 4" (10 cm) of space at the back of the vender. This will ensure proper ventilation of the refrigeration system.

To level the vender, close and latch the vender's door. Using a spirit level, adjust the four leveling legs until the top of the vender is level left-to-right and front-to-back. Make sure all leveling legs are in contact with the floor (including the support leg - see next paragraph).

### ADJUSTING THE SUPPORT LEG

The RVV is equipped with a support leg that is designed to prevent the vender from tipping. Always ensure that this leg is extended all the way to ground level. Failure to do so may result in the vender tipping forward, potentially resulting in **broken bones, dismemberment, or even death!**

The support leg is located under the bottom hinge plate of the vender's main door. Using a 1½" (38 mm) wrench, turn the leg counterclockwise until it is extended to ground level.

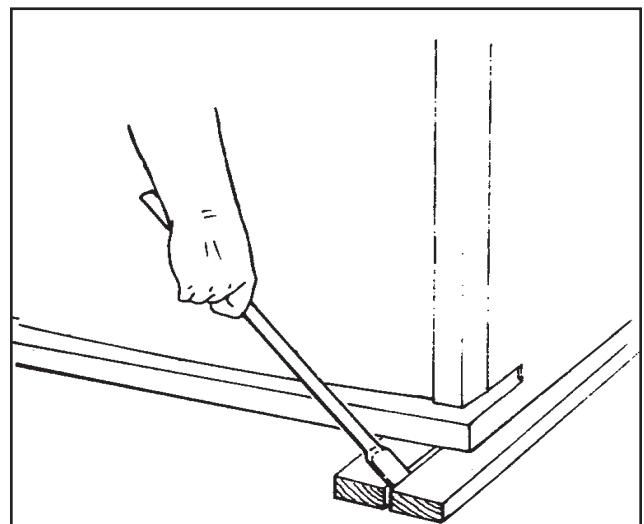

Figure 1.1

# SECTION 1: General Information and Setup

## Voltage Requirements and Vender's Power Cord

The vender is designed to operate at a voltage of 115 volts AC, 60 Hertz. It requires the minimum of a 15 amp service, and it should be on a dedicated circuit. The service outlet voltage must not exceed 129 VAC or fall below 103 VAC.

The vender has a three-wire grounding cord. The vender must be plugged into a grounded electrical outlet to protect customers from electrical shock. If the outlet is not equipped with a grounded socket, have one installed by a qualified electrician. Do not use an extension cord, unless it has been authorized by a certified electrician. Extension cords are not recommended.

After plugging the vender's power cord into the AC voltage source, the following should be observed:

1. The fluorescent bulbs will illuminate (if the door is closed);
2. The refrigeration compressor will start to run after approximately 5-7 minutes (*with the door closed*);
3. The evaporator fan will run; and
4. The Vacuum Fluorescent Display will light.

The control board is equipped with a battery back-up for use in the event of a power loss. The battery is used to retain important programming information, such as space-to-sales, prices, etc., so that it will not be erased if power is lost or the vender is unplugged.

## Programming the Vender

All programming of the vender is done in the Service Mode. To enter the Service Mode, open the vender's door, and press and release the Service Mode Button, located on the controller board. For programming instructions, see the section entitled "Vender Programming," later in this book.

## Loading the Vender

Package Loading	
Package	Qty/Col
20 oz PET	7
16 oz Glass	7
16 oz PET	8
12 oz Can	8
240 / 250 mL Can	11
14 oz PET	8
Quantities are approximate.	

**Loading Recommendations** Ensure shelf is flush with slide and tab fully engaged (both sides).

**For FIFO (first in, first out) Loading:**

1. Press down lockout bracket (right side), lift tray, and pull out slightly.
2. Release lockout bracket and pull tray out to extended position.
3. Use one hand to push package pusher back far enough to load first package with opposite hand behind existing packages.
4. Use newly loaded bottles to push stack of packages towards rear of selection. Continue until selection is full.
5. Make sure packages do not extend past tray front (see Figure 1, above).
6. When finished, press down the lockout bracket and return tray to original position (see Figure 2, above).

**For Front Loading:**

1. Load package off-center, using bottle to spread open nearest retainer. Then, rotate bottle slightly towards other retainer and into opening.
2. Continue in same manner until selection is full.
3. Make sure packages do not extend past tray front (see Figure 1, above).



# SECTION 1: General Information and Setup

## RVV Gen II Specifications

Dimensions (280 cap.) .....	72”H x 39”W x 36.5”D
Approximate Empty Weight .....	720 lbs. (327 kg)
Operating Voltage .....	115 VAC, 60 Hz
Amperage Rating .....	9 Amp
Charge .....	8.0 oz. R134a
Construction.....	Steel cabinet, plastic cells, glass front
Configuration .....	40 selections (5 shelves) 64 selections (8 shelves)

## IMPORTANT NOTE ON TRANSPORTING THE RVV

Before transporting the RVV, *always ensure that the protective transport packaging is replaced*, including:

- Packing tape to secure the case support;
- Styrofoam block on top of the motor cover, below the elevator arm;
- Binder clips to secure each belt, placed approximately in the middle of each belt’s run; and
- Cardboard to protect the glass.

Improper packaging before shipping could cause damage.

## Vender Identification

VENDER SERIAL PLATE — The vender’s main serial plate is located on the exterior left side of the vender’s main door and has the following information:

- Vender model code
- Vender serial number
- Amps required by the vender
- Unit charge of R134a
- Refrigeration design pressures

The vender’s model code contains useful information: the machine type, such as RVRVV (Royal Vendors Royal Vision Vender); the model number, such as 500; and the number 40, which designates that the vender has forty cells.

The vender’s serial number contains several important pieces of information as well. The serial number currently in use consists of the following:

- The first four numbers represent the year the vender was produced;
- The fifth and sixth digits represent the week within that year the vender was produced;
- The first letter represents the style of the vender;
- The second letter represents the location where the vender was built; and
- The last five digits represent the number of that vender built within that week.

REFRIGERATION SERIAL PLATE: The Refrigeration Serial Plate is located on the front of the vender’s refrigeration unit, mounted on the kick plate. It looks similar to the Vender Serial Plate with the exception that the model number specified is the refrigeration unit model. There is currently one model in use:

Model	Compressor size	Usage
8000V	Super 1/3 Horsepower	All RVV

## SECTION 2: Vender Component Explanation

# Vender Component Explanation

## Vender Main Controller (including pinouts)

The vender's main control board (VMC) is responsible for most vender operations. The VMC is the larger of the two printed circuit boards located in the upper left corner of the inside of the door. The boards are protected by a cover. Removing this cover will expose the boards, along with all wiring connections to the boards.

**IDENTIFICATION:** The RVV NG's VMC can be easily identified by a Royal Vendors part number decal on the capacitor of the VMC board.

**OPERATION REQUIREMENTS:** The VMC requires approximately 24 volts DC from the electronic power supply. This will allow the VMC to function and to supply power to all the vender's components listed below.

**OPERATION:** Upon receiving the appropriate voltage from the power supply, the VMC issues information to some components, receives information from some components, and communicates both ways with some components.

**VENDER MAIN CONTROLLER PINOUTS:** The RVV NG VMC has several electrical pinouts, a set-up mode button, and various other electronic components (all of which have designated position codes). The following section outlines all the VMC's pinouts.

The word *key* refers to the small plastic insert plugged into a position of the connector. The purpose of the key is to prevent connecting the harnessing backward or upside-down. The "keyed position" is a blank position within the pinout (no pin) in which a key is inserted. Some pinouts may have several blank positions with a key plugged into one or more of the positions. You can use the key to determine which end of the pinout is Pin 1.

**DEX / UCS Connections (Position P1):** The RVV NG is equipped with a DEX / UCS jack directly on the VMC at position J1. It also has pinouts for optional three (3) wire harnesses leading to internal and external jacks. The Hand Held Computer (HHC) plugs into these jacks to read information from the VMC. If the vender is equipped with these optional jacks and the HHC does not operate properly with them, check the harnesses for bad connections at the solder joints. Also check to ensure that the insulator at the jack is not cracked from over tightening.

PIN NUMBER	WIRE COLOR	FUNCTION
1	RED	VMC RECEIVE / DEX TRANSMIT DATA (ring)
2	-	FUTURE USE
3	BROWN	VMC TRANSMIT / DEX RECEIVE DATA (tip)
4	-	KEY
5	BLACK	DEX COMMON (sleeve)
6	-	FUTURE USE
7	-	KEY
8	RED	VMC RECEIVE / DEX TRANSMIT DATA (ring)
9	BROWN	VMC TRANSMIT / DEX RECEIVE DATA (tip)
10	BLACK	DEX COMMON (sleeve)

## SECTION 2: Vender Component Explanation

**Standard VFD Display Interface (Position P2):** The four-wire harness connecting to this pinout travels from the vender's VFD (Vacuum Fluorescent Display) to the VMC. It allows the VMC to send power to and communicate with the VFD. If this harness is cut or disconnected, the VFD will go blank. If this harness is pinched, you may see "broken segments" on the VFD with various segments of the display lit.

PIN NUMBER	WIRE COLOR	FUNCTION
1	RED	DISPLAY 5 VDC POWER
2	BLACK	DISPLAY CLOCK
3	BROWN	DISPLAY DATA
4	ORANGE	DISPLAY 5 VDC COMMON
5	-	KEY
6	-	VUN
7	-	MDB TRANSMIT
8	-	MDB RECEIVE

**Selection Switches (Position P3):** The RVV uses a touch pad, which utilizes a matrix wiring system. Upon pressing a particular button, a signal circuit is completed. Because each output wire carries a different signal, the controller will determine which key has been pressed based on which input wire receives the output signal.

PIN NUMBER	WIRE COLOR	FUNCTION
1	BLACK	ROW 2
2	WHITE	ROW 3
3	RED	ROW 4
4	-	NC
5	-	NC
6	-	NC
7	-	NC
8	-	NC
9	-	KEY
10	GREEN	COL 1
11	BROWN	COL 2
12	BLUE	COL 3
13	ORANGE	COL 4
14	-	NOT USED
15	YELLOW	+5VDC
16	VIOLET	GROUND

**Sold Out LEDs (Position P4) and Ready To Vend Indicators (Position P4A):** These pinouts may be available in the future, but at the time of this printing they are not available.

**24 Volt DC Power In (Position P5):** The two (2) wire harness connecting to this pinout comes from the electronic power supply. It is imperative the correct harness be connected to this pinout. If this harness is not connected (or if power is lost to this connection), you will noticeably lose all vender functions, including power to the VFD display. In addition, on venders with the optional TriTeq door lock, unless the electronic door lock is equipped with a battery backup, it will not be possible to open the vender's main door. The coin mechanism will not accept coins, and the refrigeration system will not run. With this connector, the wires can be in either position, and the control board will not be affected.

PIN NUMBER	WIRE COLOR	FUNCTION
1	-	GROUND
2	WHITE	24 VOLTS DC+
3	-	KEY
4	BLACK	24 VOLTS DC-

**Environmental Controls (Position P6):** The wiring harness connecting to this pinout powers the refrigeration relay (to power the refrigeration unit). It is also responsible for powering any optional relays, such as the refrigeration heater relay, evaporator fan relay, and light relay. It powers each relay by providing a constant 24 volts DC to each relay from Pin 1. Upon activation, the control board will remain neutral for each relay from either Pin 2, 3, 4, or 6.

PIN NUMBER	WIRE COLOR	FUNCTION
1	GREEN	24 VDC
2		HEATER RELAY
3	BLUE	COMPRESSOR RELAY
4	GREY	EVAPORATOR FAN RELAY
5	-	KEY
6	VIOLET	FLUORESCENT LIGHT RELAY
7	-	KEY
8	-	24 VDC

## SECTION 2: Vender Component Explanation

**Electronic Door Lock and Options (Position P7):** This pinout connects to the standard electronic door lock, as well as to the optional manual override switch and to the top and bottom door switches. Pin 1 receives data from the electronic door lock. This wire should never be cut, pinched, or spliced if cut. If the harness is cut, pinched, or grounded out, power will be lost to the electronic door lock. Entry into the vender will not be possible, unless the electronic door lock is equipped with an optional battery backup.

PIN NUMBER	WIRE COLOR	FUNCTION
1	WHITE	DATA FROM ELECTRONIC DOOR LOCK
2	-	NOT USED
3	-	KEY
4	-	MANUAL OVERRIDE
5	-	GROUND
6	-	KEY
7	BLACK	TOP DOOR SWITCH
8	-	COIN SENSOR
9	-	5 VDC
10	BLACK	BOTTOM DOOR SWITCH
11	-	24 VDC
12	-	KEY
13	-	VEND COUNTER

**Temperature Sensors (Position P8):** The wiring harnesses connecting to this pinout travel from the temperature sensor and optional health sensor to the control board. The temperature sensor is mounted adjacent to the evaporator fan inlet. These harnesses are molded into the temperature sensor and health sensor, and they should never be cut, pinched, or spliced together if cut. If the harness is cut, pinched, or improperly grounded, the sensor may give the control board false temperature readings. Refrigeration activity is based on the signal reported to the control board from these sensors.

PIN NUMBER	WIRE COLOR	FUNCTION
1	RED	TEMP. SENSOR +5 VDC
2	WHITE	TEMP. SENSOR SIGNAL
3	-	KEY
4	BLACK	TEMP. SENSOR GROUND
5	RED	HEALTH SENSOR +5 VDC
6	WHITE	HEALTH SENSOR SIGNAL
7	-	KEY
8	BLACK	HEALTH SENSOR GROUND

**Multi-Drop Bus (Position P9):** The five-wire serial harness connecting to this pinout provides power and communications to and from the control board for the coin mechanism, the optional 24 VDC bill validator, and/or the optional debit card reader, as well as the electronic door lock. If this harness is cut, pinched, or disconnected, you will noticeably lose power to these items. *Note: This harness also connects to the DMC at position P6.*

PIN NUMBER	WIRE COLOR	FUNCTION
1	WHITE	24 VDC
2	BROWN	RETURN
3	-	NOT USED
4	BLACK	RECEIVE
5	RED	TRANSMIT
6	GREEN	COMMON

**Vend Motors (Position P10):** This pinout is not currently used.

**Port Power (Position P11):** The harness connecting to this pinout should never be cut, pinched, or spliced if cut. The delivery sensors are located in the port area of the vender's main door. The emitter is located below the port; the receiver is located above the port. *Note: This harness also connects to the DMC at position P4.*

PIN NUMBER	WIRE COLOR	FUNCTION
1	RED	+5 VDC DELIVERY SENSOR
2	WHITE	GROUND DMC LOOP (ORANGE)
3	-	NC
4	-	+5 VDC
5	BLACK	DEL. DOOR SW. GROUND

**Delivery Sensor (Position P14) and Parallel Display (Position P15):** These pinouts are not currently used.

## SECTION 2: Vender Component Explanation

### Delivery Mechanism Controller (including pinouts)

The vender's delivery control board (DMC) is responsible for delivery operations. The DMC is the smaller of the two printed circuit boards located in the upper left corner of the inside of the door. Along with the VMC, the DMC is protected by a cover. Removing this cover will expose the boards and all wiring connections to the boards.

**Y-Axis (Position P1):** The Y-axis is the up and down movement of the product elevator.

PIN NUMBER	WIRE COLOR	FUNCTION
1	BLACK	Y-AXIS ENC GROUND
2	RED	Y-AXIS ENC 5 VDC
3	WHITE	Y-AXIS ENCODER CHANNEL B
4	GREEN	Y-AXIS ENCODER CHANNEL A
5	BLACK	5 VDC Y-AXIS HOME SWITCH
6	RED	COMMON Y-AXIS HOME SW.
7	-	+5 VDC
8	BLACK	Y-AXIS PHASE A-
9	-	NOT USED
10	RED	Y-AXIS PHASE A+
11	-	NOT USED
12	GREEN	Y-AXIS PHASE B-
13	-	NOT USED
14	WHITE	Y-AXIS PHASE B+

**X-Axis (Position P2):** The X-axis is the left and right movement of the product elevator.

PIN NUMBER	WIRE COLOR	FUNCTION
1	BROWN	X-AXIS ENC GROUND
2	YELLOW	X-AXIS ENC 5VDC
3	-	NOT USED
4	WHITE	X-AXIS ENCODER CHANNEL A
5	GREEN	X-AXIS ENCODER CHANNEL B
6	-	GROUND
7	BROWN	X-AXIS PHASE B-
8	YELLOW	X-AXIS PHASE B+
9	-	NOT USED
10	-	NOT USED
11	GREEN	X-AXIS PHASE A-
12	WHITE	X-AXIS PHASE A+

**Delivery Cup (Position P3):** This harness connects to the delivery cup assembly board.

PIN NUMBER	WIRE COLOR	FUNCTION
1	BLACK	GROUND
2	BROWN	PRODUCT DETECT
3	RED	TACHOMETER SENSE
4	YELLOW	POSITION SENSE
5	GREEN	5 VDC
6	BLUE	PLUNGER MOTOR -
7	GREY	PLUNGER MOTOR +
8	-	NOT USED
9	PINK	DRIVE MOTOR +
10	WHITE	DRIVE MOTOR -

**Port Sensors (Position P4):** The harness connecting to this pinout should never be cut, pinched, or spliced if cut. The delivery sensors are located in the port area of the vender's main door. The emitter is located below the port; the receiver is located above the port. *Note: This harness also connects to the VMC at position P11.*

PIN NUMBER	WIRE COLOR	FUNCTION
1	-	+5 VDC
2	RED	PORT DETECT
3	BLACK	DELIVERY DOOR SWITCH
4	BROWN	GROUND
5	-	NOT USED
6	ORANGE	GROUND VMC LOOP (WHITE)

**Multi-Drop Bus (Position P6):** The five-wire serial harness connecting to this pinout provides power and communications to and from the VMC and DMC for the coin mechanism, the optional 24 VDC bill validator, and/or the optional debit card reader, as well as the electronic door lock. If this harness is cut, pinched, or disconnected, you will noticeably lose power to these items. *Note: This harness also connects to the VMC at position P9.*

PIN NUMBER	WIRE COLOR	FUNCTION
1	WHITE	24 VDC
2	BROWN	RETURN
3	-	KEY
4	BLACK	RECEIVE
5	RED	TRANSMIT
6	GREEN	COMMON

## SECTION 2: Vender Component Explanation

---

### Touch Pad

The 12-button touch pad is located on the right side of the door front. The touch pad contains the numbers 0-9, plus the \* key and the # key. All programming and sales selections are done by way of the touch pad.

### Delivery Sensor

The delivery sensor actually consists of two separate components which work in conjunction with one another. The emitter, below the product delivery port, emits an infrared beam. The receiver, above the delivery port, receives the infrared beam. When a product falls into the delivery port, the infrared beam is broken, signalling to the DMC board that a vend has been made.

### Door Switches

There are two door switches mounted on the door's chassis. The door switches are actuated by the door each time it is opened or closed. The following functions are performed each time the vender door is closed:

1. All sold-out selections are cleared;
2. The greeting scrolls on the display;
3. If door switch reset is enabled in programming, the resettable MIS counters will be reset if at least one selection has been read;
4. A 5-7 minute delay begins after which the refrigeration unit will come on; and
5. The door lights will turn on.

### Vacuum Fluorescent Display (VFD)

The VFD, a two-line, 20-character per line display, is located above the validator. All information to the programmer and to the customer is conveyed on the VFD.

### Electronic Power Supply

The Royal Vision Vender NG uses an electronic power supply which converts 115 volts AC (conventional voltage) to 24 volts DC, to power the vender's control board. The electronic power supply is a major contributor to the vender's operation. Without it, the control board cannot function.

**LOCATION OF ELECTRONIC POWER SUPPLY:** The power supply is located in the bottom of the vender's door. It is contained in a metal tray which also holds the light ballast and the fusebox assembly. To remove this metal tray, remove the screw from each end of the tray with a Phillips screwdriver. **WARNING:** Before removing this tray, remove power from the vender by unplugging the main power cord from the AC voltage source (wall outlet)!

**CHECK THE POWER SUPPLY AND FUSE:** If upon arriving at the vender the display is not lit, the coin changer does not take coins or payout coins, and the door lights are not lit, make sure the vender is plugged in. Next, check the external 3-amp fuse for visual damage. Check for continuity across the fuse with a voltage meter or similar device. If defective, replace the external fuse.

1. Check the power going into the power supply at the connected red and black wires. It should register 115 volts AC. If not, check all wiring leading up to this point from the bottom of the vender's door. The power supply may not be the problem. There may be a broken wire or bad connection.
2. If 115 volts is registered in Step 1, measure voltage coming out of the power supply. The two-pin connector at the VMC connected to position P5 should register approximately 24 volts DC. If so, check the control board; the power supply is good.
3. If 115 volts is registered in Step 1 and 24 volts is NOT registered in Step 2, the electronic power supply is probably bad. Unplug the vender, and unplug the connections at the power supply (115-volt and 24-volt side). Remove the power supply from the door. Replace it with a new electronic power supply.

## SECTION 2: Vender Component Explanation

### Refrigeration System

The vender's refrigeration system is responsible for the cooling of the cabinet and the products loaded within it. The refrigeration system comes as a completely sealed unit and should never be cut or tapped into, or the warranty will be voided.

#### OPERATION REQUIREMENTS

The refrigeration system requires 115 volts AC from the main wiring harness for it to operate. The main wiring harness will get its voltage for the unit from the refrigeration relay.

#### COOLING SOFTWARE FEATURES

The RVV NG controller software includes the following refrigeration modes and features:

- **Normal Mode (Energy Saving):** When the main door is closed and switches are made, the controller counts the number of refrigeration cycles. When this number equals a stored counter, the refrigeration unit converts from a pull-down mode, in which the evaporator fan runs continuously, to a normal mode, in which the evaporator fan runs only when the compressor is on. This process normally takes about 24 hours after the door is shut, with a complete product reload in a 75°F (24°C) ambient environment.
- **Defrost Mode:** The defrost feature is a 30-minute period in which the compressor is shut off and the evaporator fan is allowed to run. The defrost feature is initiated by a timer. The factory setting is three hours, but this setting may be adjusted in the service menu.

If the unit is already in the defrost mode when the door is opened, the defrost function will continue after the door is closed. Because of that, the compressor may not restart for as much as 30 minutes after the door is closed.

- **Door Switch Inactivation Mode:** If the door switch does not activate, the fluorescent lights will stay off and the refrigeration unit will not run until 30 minutes have passed. After 30 minutes, the controller will assume that the switch may be defective and will then start the cooling process. In this mode, the evaporator fan will cycle with the refrigeration unit (similar to Normal Mode, but without the counter).
- **Compressor Motor Save Mode:** If the controller calls for cooling continuously for 24 hours, the

vender will go into a defrost mode for one hour. If the refrigeration unit still does not cycle after an additional eight hours, a no pull-down error will be displayed. *(In software versions 67241-6 and lower, the refrigeration system will shut down when the no-pulldown error is recorded. This feature protects the compressor motor against overheating if running against an iced evaporator for an extended period. If the Health Timer is enabled, the operation is the same except that the compressor will not be shut down.)*

**Note:** This no pull-down error is not self-clearing; it must be cleared manually through the service menu or through DEX.

#### HEALTH SENSOR OPERATION

The rising temperature in the cooling compartment is reported to the VMC board by the temperature sensor. At power up, the VMC will check for the temperature. If the temperature is above 41°F (5°C), the vender will display "Out of Order." Once the "Health Safety Failed" error has been cleared, a 30-minute timer will begin. At the end of this 30 minutes, the vender will stay in normal operating mode as long as the temperature remains 41°F (5°C) or below. If the vender is 41°F (5°C) or below at power up, the vender will stay in normal operating mode. If the door is open after power up and the temperature is 41°F (5°C) or below and stays at 41°F (5°C) or below, a 30-minute timer will start after the door is closed. If the temperature is above 41°F (5°C) after 30 minutes, the vender will display "Out of Order." Any time the vender is in a normal operating mode and the temperature reaches above 41°F (5°C), a 15-minute timer will start. If after 15 minutes the temperature remains above 41°F (5°C), the vender will display "Out of Order."

#### REFRIGERATION COMPONENTS

The refrigeration system is a sealed system. Described in this section are explanations of the refrigeration system's major components.

**Compressor** - The compressor is a hermetically-sealed unit located beneath (outside) the cooling compartment. The compressor is a pump, driven by the compressor motor which draws low-pressure vapor (refrigerant) from the evaporator coil, compresses it, and forces it into the condenser under high pressure. The motor is started and controlled by the refrigeration relay.

**Condenser** - The condenser is located beneath (outside) the cooling compartment next to the compressor. It can be seen from the front with the door open. The condenser removes heat from the high-pressure vapor discharged from the compressor and condenses it to a high-pressure liquid. The

## SECTION 2: Vender Component Explanation

condenser and evaporator coils have aluminum fins attached to effectively increase heat exchange surfaces.

**Starting Relay** - The starting relay is mounted on the side of the compressor housing. The compressor motor has two windings (start winding and run winding). To give the motor torque when it first starts, the starting relay switches in the additional start winding. After the motor gets up to speed, the relay opens the start winding and the motor continues using only the run winding.

**Thermal Overload** - The thermal overload is a heat-sensitive device mounted on the side of the compressor housing. If the compressor motor gets too hot or draws an excessive amount of current, the thermal overload will open, breaking the circuit to the compressor. After the compressor cools to a safe operating temperature, the thermal overload will close, allowing the compressor and condenser fan motors to restart.

**Condenser Fan and Motor** - The condenser fan and motor, located beneath the cooling department, are a forced-air device using outside ambient air to cool the surface of the condenser coil. The condenser fan and motor run while the compressor operates.

**Evaporator Coil** - The evaporator coil is located in the cooling compartment. As low pressure liquid passes through the evaporator coil, it absorbs and removes heat from the compartment as it changes to vapor. The condenser and evaporator coil have aluminum fins attached to effectively increase their heat exchange surfaces.

**Evaporator Fan and Motor** - The evaporator fan and motor are a forced-air device circulating air throughout the cooling compartment and over the heat exchange surface of the evaporator coil.

**Expansion Valve** - The expansion valve is located in the refrigerant line between the condenser and evaporator coils. The expansion valve is used as a metering device to control the flow of liquid refrigerant to the evaporator coil. This creates a low pressure causing the refrigerant to vaporize and absorb heat as it passes through the evaporator.

**Drier** - The drier is located in the refrigerant line between the capillary tube and condenser. It traps and removes moisture from the refrigeration system while allowing oil and refrigerant to pass through the system.

**Accumulator** - The accumulator is located in the refrigerant line between the evaporator coil and the compressor. The accumulator traps any liquid refrigerant which did not vaporize before it reaches the compressor.

**Refrigeration Relay** - The refrigeration relay is located in the lower left section of the vender's cabinet near the main wiring harness. The refrigeration relay is responsible for powering the compressor and condenser fan motors. The refrigeration relay consists of a coil powered by the control board (24 VDC) and a switch. When the control board completes the circuit to the refrigeration relay, the relay will energize, closing the contact between the common and the normally-open positions. When this happens, power (115 VAC) travels from the refrigeration relay to the main wiring harness for the refrigeration unit.

### REFRIGERATION SYSTEM

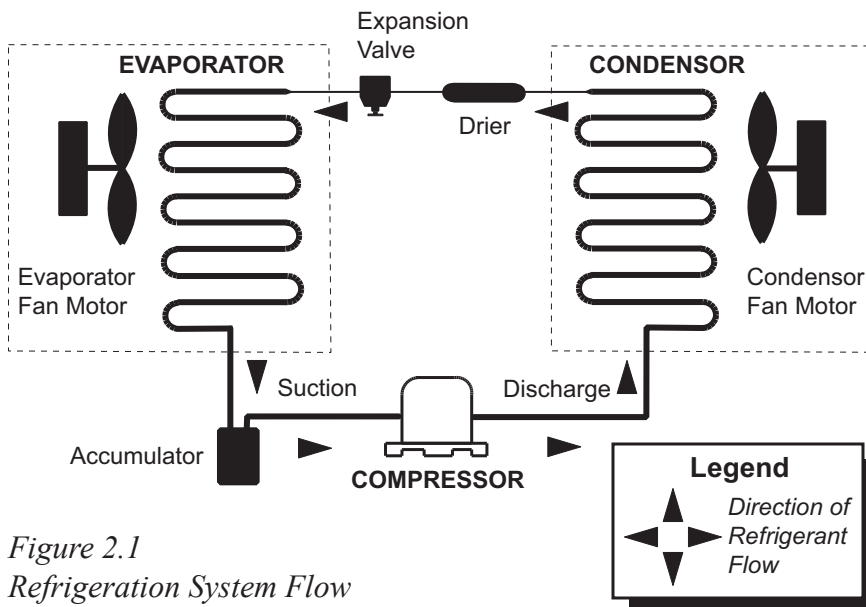

Figure 2.1  
Refrigeration System Flow

### REFRIGERATION CYCLE

1. The rising temperature in the cooling compartment is reported to the control board through the temperature sensor.
2. The control board registers the current temperature inside the vender's cabinet. When it rises equal to or above the pre-programmed cut-in temperature, the control board will complete the circuit to the refrigeration relay to energize its coil.
3. The refrigeration relay coil closes the contact between the common and normally-open positions, allowing 115 volts to travel to the main wiring harness to start the compressor.
4. The compressor circulates



## SECTION 2: Vender Component Explanation

refrigerant throughout the system by pulling low-pressure refrigerant vapor from the evaporator coil, compressing it, and forcing it into the condenser. The condenser, aided by the condenser fan motor, removes heat from the refrigerant as it flows through the condenser and releases it to the outside environment. The dropping of the refrigerant temperature changes the vapor to liquid.

5. The evaporator coil allows the liquid refrigerant to absorb heat from the cooling compartment as it evaporates in the coil.
6. The falling temperature in the cooling compartment is caused by the continual circulation of refrigerant through the system, removing heat from the cooling compartment and transporting it to the outside environment. When the temperature drops, the temperature sensor reports this to the vender's control board.
7. When the temperature drops below the preset cut-out temperature, the control board will disable the refrigeration relay, thus killing power to the refrigeration unit.

### TESTING THE REFRIGERATION SYSTEM

1. The sealed refrigeration unit can be tested by unplugging it from the top of the main wiring harness and plugging it directly into a power source. If the unit still does not operate, a problem exists within the sealed unit.
2. If the sealed unit runs when plugged into an external power source, the problem more than likely lies between the control board, the refrigeration relay, and the main wiring harness.

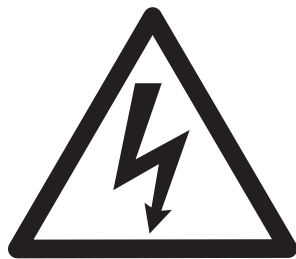

### WARNING

#### ELECTROCUTION HAZARD

When plugging the refrigeration unit directly into a wall outlet or other external electrical source, the refrigeration unit **MUST** remain in the vender for proper grounding. If the unit is removed from the vender, an electrocution hazard exists.

### Ballast

The ballast acts as a transformer to convert conventional voltage (115 VAC) to a higher voltage required to energize the vender's fluorescent lights (upwards of 600 VAC). The ballast is located in a metal tray in the bottom of the vender's door, along with the electronic power supply and the fusebox assembly. To remove this metal tray, remove the screw from each end of the metal tray with a Phillips screwdriver.



**WARNING: Before removing the ballast tray, remove power from the vender by unplugging the main power cord from the AC voltage source (wall outlet)!**

### Credit Peripherals

There are three possible credit peripherals for the RVV NG: the coin changer, bill acceptor, and debit card reader. The coin changer determines the validity and value of each coin that is inserted into the vender and sends the coin information to the vender controller. The coin changer also continuously informs the vender controller if coins are available in the change tubes to be used for change payout. The bill acceptor determines the validity and value of each bill that is inserted and sends that information to the vender controller. The debit card reader allows customers to purchase a product using a debit or credit card. For detailed information on any of the credit peripherals, refer to the separate operation and service manual provided by the peripheral's manufacturer.

## SECTION 2: Vender Component Explanation

---

### TriTeq Electronic Door Lock

Some venders may be equipped with the TriTeq electronic door lock system. The TriTeq electronic door lock provides the control board with one signal line to determine the status of the door and lock. It consists of a motor-driven bolt (mounted on the door), an electronic nut receptacle (mounted on the cabinet), an infrared signal receiver, and an infrared key. The infrared code for this lock cannot be decoded if the key is lost or stolen. If the key is lost or stolen, it will be necessary to change the lock code as soon as possible. It is not necessary to replace the lock in order to re-key it.

Loss of power to the electronic door lock will prevent entry to the vender, unless it has been equipped with an optional battery. With the battery installed, it will be possible to open the vender's door in the event of a power loss.

The TriTeq electronic door lock system is not available for purchase from Royal Vendors. To order any component of the electronic door lock system or for more information, contact:

TriTeq Lock and Security  
701 Gullo Avenue  
Elk Grove Village IL 60007  
Tel. 847-640-7002  
Fax 847-640-7008  
E-mail: sales@triteqlock.com  
Website: www.triteqlock.com

#### OPENING THE RVV DOOR

Make sure power is applied to the electronic door lock, either by way of the vender being plugged into a standard 115 VAC receptacle or by the TriTeq lock override battery. Aim the infrared key at the detector hole (below the VFD), about 1-3 inches (about 3-8 cm) away from it, and press the button on the key. The VFD will display "Door Opening," and the door will begin to unlock. After the door is opened, the display will show "Door Unlocked."

#### CLOSING THE RVV DOOR

Gently push the door to the cabinet. **Do not slam the door.** The lock motor will begin to run, and the VFD will display "Door Closing." Hold the door firmly until the nut has grasped the bolt. The motor will continue to run until the door is closed tightly. Check to make sure the door is secure.

# SECTION 3: Vender Programming

## Vender Programming

### PRECAUTIONS TO TAKE WHEN WORKING WITH CONTROL BOARD

As with any printed circuit board, our electronics are very sensitive to Electrostatic Discharge (ESD). Simply walking across a tile or carpeted floor can generate a range of 30,000 to 50,000 volts of electricity. One ESD can be enough to seriously damage your control board or at least weaken it enough that erratic problems could occur in the future. Even a discharge surge under 100 to 200 volts is enough to create problems within the circuitry of the electronics. It is advised when storing the electronics that they be kept in anti-static bags, even if the electronics are thought to be defective. If a control board is thought to be defective and is really not, it soon will be after being charged with ESD. The ideal prevention against ESD is to use anti-static conductive wrist straps which ground you to the machine before touching the electronic boards. If it is not possible to use these, at least ground yourself before handling the electronic boards by touching the metal framework of the vender. Whatever method you use, always handle the electronic boards by the edges. Be careful not to touch the components on the control board.

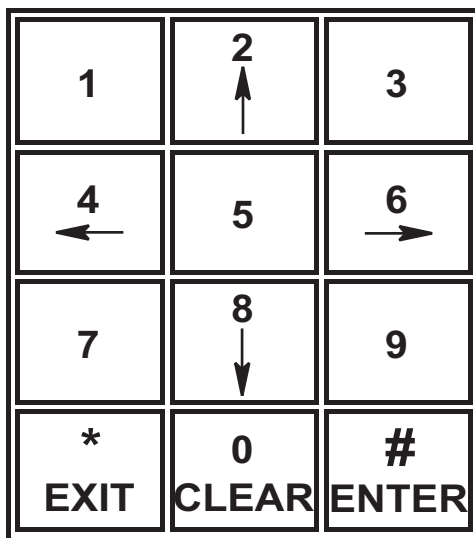

Figure 3.1  
Touch Pad

### TOUCH PAD PROGRAMMING

It is very important that the RVV is programmed properly. All programming of the vender options is done in the Service Mode. To enter the Service Mode, open the vender door, and press and release the blue mode button located on the control board.

The vender's touch pad consists of 12 buttons. Five of these buttons (see Figure 3.1, below left) are used to program the vender and navigate through the service routines, plus two are used to move the elevator cup (in "Product Location"), as follows:

Button	Meaning	Usage
2	FORWARD	Increase, next, up
4	LEFT	Move elevator cup left
6	RIGHT	Move elevator cup right
8	BACKWARD	Decrease, previous, down
0	CLEAR	Clear errors
*	EXIT	Escape, cancel, exit
#	ENTER	OK, accept, save

The controller will automatically return to the Sales Mode if:

- No response from the touch pad is received for approximately five minutes;
- The service mode button is pressed a second time;
- The "Return" mode is activated (with door open); or
- The door is actually closed.

If credit exists, the credit amount will be displayed after returning to the Sales Mode.

### MENU SYSTEM

When programming, you must first use the programming buttons listed above to maneuver through menus and sub-menus before you will be allowed to accomplish your task. Each menu consists of various items, or modes, such as "Set Prices" Mode or the "Set Time / Date" Mode. There are two menus:

1. INTERNAL (Service) MENU - This menu is available only with the vender's door open. It is accessed upon pressing the control board's mode button.
2. EXTERNAL MENU - This menu is available by entering the proper external password with the vender's door closed. (See "Preview Password" in the following section.) From this menu, cash / sales counts and vender errors can be read (but not cleared).

*Note:* Programming flowchart located in rear of manual.

## SECTION 3: Vender Programming

# Internal (Service) Menu

### Cash Counters

If <enter> is pressed at the “Cash Counters” prompt, the controller will enter the non-resettable cash display mode by displaying “Cash Total X.XX,” where the X’s will represent total cash over the life of the vender’s control board. Using <up> or <down> will cycle through each selection as “Cash Sel N X.XX,” where “N” represents the appropriate selection number and the X’s represent the resettable cash count for that selection. If <exit> is pressed at anytime during this operation, the controller will return to the code level. Press the <up> button to proceed to the next prompt, “Sales Counters.”

### Sales Counters

If <enter> is pressed at the “Sales Counters” prompt, the controller will enter the non-resettable sale count display mode displaying “Sales Total XXX,” where the X’s represent the number of all paid vends over the life of the vender’s control board. Using <up> or <down> will cycle through each selection as “Sales Sel N XXX,” where “N” represents the appropriate selection number and the X’s represent the resettable number of vends for that selection. If <exit> is pressed anytime during this operation, the controller will return to the “Sales Counters” prompt. Press <up> to proceed to the next prompt, “Card Counters.”

### Card Counters

If <enter> is pressed at the “Card Counters” prompt, the controller will enter the card counter display mode by displaying “Total Vends XXXXXXXX” on the first line and “Value YYYYYY.YY” on the second line. The X’s represent the number of all card vends over machine life, and the Y’s represent the value of all card sales over machine life. Using <up> or <down> will cycle through each selection by displaying “Sel N Vends XXXXXXXX” on the first line and “Value YYYYYY.YY” on the second line. “N” will represent the selection number. The individual counts are resettable. If <exit> is pressed anytime during this operation, the controller will return to the “Card Counters” prompt. Press <up> to continue to the next prompt, “Token Counters.”

### Token Counters

If <enter> is pressed at the “Token Counters” prompt, the controller will enter the token counter display mode by displaying “Total Vends XXXXXXXX” on the first line and “Value YYYYYY.YY” on the second line. “Token Counters” functions exactly as “Card Counters” does, except that it counts token vends instead of card vends. (See above.) If <exit> is pressed anytime during this operation, the controller will return to the “Token Counters” prompt. Press <up> to proceed to the next prompt, “Free Vend Accounting.”

### Free Vend Accounting

If <enter> is pressed at the “Free Vend Accounting” prompt, the controller will enter the first of two sub-menus, “Free Vend Counters.” Pressing <up> or <down> will cycle to the other menu: “View Selection Costs.”

If <enter> is pressed at the “Free Vend Counters” prompt, the controller will enter the cash value display mode by displaying “Total Vends XXXXXXXX” on the first line and “Value YYYYYY.YY” on the second line. The X’s represent the number of all free vends over machine life, and the Y’s represent the value of all free vends over machine life.

Using <up> or <down> will cycle through each selection by displaying “Sel N Vends XXXXXXXX” on the first line and “Value YYYYYY.YY” on the second line, where “N” indicates the selection number, the X’s represent the number of free vends since the last reset, and the Y’s represent the equivalent value of free vend sales since the last reset. If <exit> is pressed anytime during this operation, the controller will return to the “Free Vend Accounting” prompt.

If <enter> is pressed at the “View Selection Costs” prompt, the controller will enter the free vend equivalent cost display mode by displaying “Sel N Cost XX.XX,” where the X’s represent the last saved price that is not \$00.00 for that selection. A decimal will be displayed in the appropriate position. Using <up> or <down> will cycle through each selection. If <exit> is pressed anytime during this operation, the controller will return to the “Free Vend Accounting” prompt. Press <up> to proceed to the next prompt, “Error Codes.”

## SECTION 3: Vender Programming

### Error Codes

If <enter> is pressed at the “Error Codes” prompt, the controller will enter the error display mode. If no errors have occurred since the last error reset, the display will show “No Errors.” If an error has been detected since the last error reset, the display will show the first summary error code that has occurred, such as “Vend Mechanism,” which would indicate a vend error. Pressing <up> or <down> will allow you to cycle through all of the summary error codes that are present. Pressing <enter> at the displayed summary error code will allow you to view the detailed error codes beneath the summary error heading (see below). Pressing <up> or <down> at this point will allow you to cycle through all of the detailed error codes that are present beneath the summary error code. If the <exit> button is pressed anytime during this operation, the controller will return to the “Error Codes” prompt. Press the <up> button to proceed to the next prompt, “Test Modes.”

If the <clear> button is pressed during the display of any detailed error code, that error will be cleared. If other errors exist that fall under the currently accessed detail type, the next error would be displayed. If no other errors of the current type exist, the next error summary code will be displayed, or “No Errors” will be displayed if no other errors exist.

The error summary codes and their corresponding detailed error codes are as follows:

- **Control System**

By pressing <enter> at the “Control System” prompt, the controller will display:

1. “Door Switch,” indicating the door switch has been open for more than an hour;
2. “RAM Checksum,” indicating the machine setup information has been corrupted;
3. “DC Under Voltage,” indicating that the average rectified voltage was under 20VDC for more than 30 seconds;
4. “DC Over Voltage,” indicating that the average rectified voltage was over 45VDC for more than 30 seconds;
5. “System Scale Factor,” indicating one of the credit peripherals has introduced an incompatible scaling factor;
6. “Inlet Sense,” indicating the machine’s coin inlet sensor has been blocked for more than a minute (*note: this is an optional component not installed on all venders*); or

7. “Inlet Blocked,” indicating two coins were sensed at the inlet sensor but didn’t make it to the changer within 10 seconds.

After taking corrective action to manually fix the “Control System” errors, the errors may be cleared electronically via a hand held device or through the service mode using the <clear> button.

- **Selection Switch**

By pressing <enter> at the “Selection Switch” prompt, the controller will display “Selection Switch XX,” where “XX” indicates the first selection switch that has been determined to be closed for more than 15 seconds. If there is a selection key error, navigation of the service menu will not be possible. This error can only be cleared by manually correcting or replacing the keypad.

- **Changer**

By pressing <enter> at the “Changer” prompt, the controller will display either:

1. “Changer Comm,” indicating no changer communications for more than 2 seconds;
2. “Tube Sense,” indicating a tube sensor error;
3. “Changer Inlet,” indicating no coins sensed by acceptor for over 96 hours;
4. “Tube Jam XX,” indicating a tube jam error for coin type XX;
5. “Changer ROM,” indicating a changer ROM checksum error;
6. “Excessive Escrow” indicating more than 255 escrow attempts since the last coin was accepted;
7. “Coin Jam,” indicating a coin jam;
8. “Low Acceptance,” indicating a low acceptance rate (more than 20% of the last 255 coins were slugs);
9. “Disconnected Acceptor,” indicating an unplugged acceptor; or
10. “Misrouted Coin,” indicating a coin had been improperly routed.

The “Changer Comm” error will be cleared when proper communications are re-established. After taking corrective action to manually fix the other “Changer” problems, the errors may be cleared electronically via a hand held device or through the service mode using the <clear> button.

## SECTION 3: Vender Programming

---

- **Bill Validator**

By pressing <enter> at the “Bill Validator” prompt, the controller will display either:

1. “Bill Val Comm,” indicating no bill validator communications for more than 5 seconds;
2. “Bill Stacker Full,” indicating a full bill stacker;
3. “Bill Motor,” indicating a defective motor;
4. “Bill Jam,” indicating an bill jam error;
5. “Bill Val ROM,” indicating a bill acceptor ROM check sum error;
6. “Open Cash Box,” indicating an open cash box; or
7. “Bill Sensor,” indicating a bill sensor error.

The “Bill Val Comm” error will be cleared when proper communications are re-established. After taking corrective action to manually fix the other “Bill Validator” problems, the errors may be cleared electronically via a hand held device or through the service mode using the <clear> button.

- **Card Reader**

By pressing <enter> at the “Card Reader” prompt, the controller will display either:

1. “Card Reader Comm,” indicating no card reader communications for more than 5 seconds; or
2. “Card Reader Error XY,” indicating that a particular type of card reader malfunction occurred where “XY” indicates the error type.

The “Card Reader Comm” error will be cleared when proper communications are re-established. The “Card Reader Error XY” errors may be reset via the hand held device or through the service mode using the <clear> button.

- **Vend Mechanism**

By pressing <enter> at the “Vend Mechanism” prompt, the controller will display either:

1. “Delivery System,” indicating that there is a generic vend mechanism error;
2. “Cup Sensor,” indicating that the cup sensor has malfunctioned;
3. “Home Sensor,” indicating that the DMC home sensor has malfunctioned;
4. “Critical Mech,” indicating a critical vend mechanism error has occurred;
5. “USD Comm,” indicating that the Universal Satellite Device (i.e., the DMC) is no longer online;

6. “Delivery Port Sense,” indicating that the DMC is reporting a port sense error; or
7. “Delivery Port Door,” indicating that the DMC is reporting a port door error.

After taking corrective action to manually fix the “Vend Mechanism” errors, the errors may be cleared electronically via a hand held device or through the service mode using the <clear> button.

- **Space to Sales**

By pressing <enter> at the “Space to Sales” prompt, the controller will display “Unassigned Cell XX,” indicating that cell XX is unassigned. These errors are cleared when new space to sales programming resolves the errors or via the service mode using the <clear> button. (*Note: When an unassigned cell is selected in the sales mode, the display will show “No Sales Available.”*)

- **Refrigeration**

By pressing <enter> at the “Refrigeration” prompt, the controller will display either:

1. “Temperature Sensor,” indicating an unplugged temperature sensor error;
2. “Too Cold,” indicating temperatures 3° F (1.5° C) below the compressor cut-out setting;
3. “Too Hot,” indicating temperatures 3° F (1.5° C) above the compressor cut-in setting;
4. “Compressor,” indicating that the compressor is not cooling at 1° F (0.5° C) per hour or better while on;
5. “Heater,” indicating that the heating system is not heating at 1° F (0.5° C) per hour or better while on;
6. “No Pulldown,” indicating an inability to reach the set point temperature; or
7. “Health Safety Failed,” indicating that the health safety limit temperature has been violated.

The “Temperature Sensor” error will be cleared if the sensor is detected. The “Too Cold” error will be cleared when the temperature rises above the cut-out limit. The “Too Hot” error will be cleared when the temperature falls below the cut-in limit. The “Compressor” error will be cleared when the system cools at 1° F (0.5° C) per hour or better. The “Heater” error will be cleared when the system heats at 1° F (0.5° C) per hour or better. The “Pulldown” error must be manually cleared electronically via a hand held device or through the service mode using the <clear> button. All other “Refrigeration” errors can also be cleared via the hand held device or through service mode using the <clear> button.

## SECTION 3: Vender Programming

### Test Modes

If <enter> is pressed at the “Test Modes” prompt, the controller will enter the test mode by displaying “Test Vend”. Using <up> or <down> will allow you to cycle through the available tests. If <exit> is pressed at anytime, the controller will return to the “Test Modes” prompt. Use <up> to proceed to the next prompt, “Set Prices.”

- **Test Vend**

If <enter> is pressed at the “Test Vend” prompt, the controller will enter the test vend routine. This routine will allow the operator to test the functionality of the vending mechanism and of the individual cells. At this point, the door can be closed, and the controller will remain in the test vend mode. **Note:** *The vend mechanism will home upon shutting the door.* When the door is closed, and no activity occurs for five minutes or the “Test Vend” routine is left, the controller will exit the service modes. Using <up> or <down> will cycle through all the available cells, displayed as “Cell XX” and “Vend All.” If <enter> is pressed at the “Cell XX” prompt, a vend will be attempted on that cell. If <exit> is pressed at any time, the controller will return to the “Test Vend” prompt. Pressing <enter> at “Vend All” will vend sequentially from cell 11 all the way to the last cell. If <exit> is pressed during the “Vend All” test, the sequential vending will be stopped. Press <exit> at “Vend All” to return to the “Test Vend” prompt. Press <up> to proceed to the next prompt, “Test Select Switches.”

- **Test Select Switches**

If <enter> is pressed at the “Test Select Switches” prompt, the controller will enter the selection switch test mode. The display will show “Selection 12,” the switch number of the <enter> key. With each subsequent press of a selection switch, the display will show that particular selection switch number on the display. Keys labeled 1-9 are displayed as “1” to “9”; the \*, 0, and # keys are displayed as “10,” “11,” and “12,” respectively. To exit the selection switch test mode, hold the <exit> key for more than 3 seconds. This will return the controller to the “Test Select Switches” prompt. Press the <up> button to proceed to the next prompt, “Calibrate.”

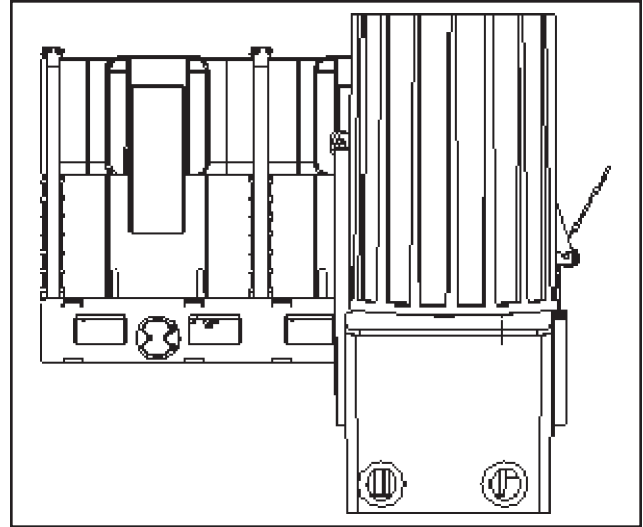

Figure 3.2.

- **Calibrate**

Pressing <enter> at the “Calibrate” prompt will cause the controller to enter the vend mechanism calibration routine. This routine allows the operator to calibrate shelf and delivery port positions. Upon entry into this routine, the display will show “Password.” Pressing <up> or <down> will scroll through menu options “Password,” “Shelf,” “Shelf X, Position 1,” and “Port X.”

Pressing <enter> at the “Password” prompt will cause the controller to wait for the calibration password. The display will go blank and display an asterisk for each of the four characters. If the password is correct, the display will show “Cabinet”; otherwise, the display will show “Calibration.” The calibration password is “3456.” If the password is entered correctly, “Saved” will be shown whenever the user attempts to save a position or a shelf number. Otherwise, the system displays “Not Saved.” **Note:** *“Password” will be removed from the menu once the correct password has been entered. If the controller is taken out of “Calibrate,” the password will need to be re-entered.*

Pressing <enter> at the “Cabinet” prompt will cause the controller to display the current setting for the cabinet type. When installed in the RVV Gen II, the controller should always be set to “Gen II.” If set incorrectly, press <up> until the correct cabinet setting is displayed; then, press <enter>. The display will return to the “Cabinet” prompt. Press <up> to go to the next prompt, “Shelf.”

## SECTION 3: Vender Programming

Pressing <enter> at the “Shelf” prompt will cause the controller to display the current number of shelves the system believes are available. Pressing <up> or <down> will cycle through the number of shelves available (5 - 8). Pressing <enter> will save a new total of shelves available across the system. Pressing <exit> will return the user to the “Shelf” prompt.

**Note:** It is up to the user to correctly set the number of shelves that is in use by the system. Changing the number of shelves in use by the system will require the vender to be recalibrated. In addition, selection settings (“Price Program,” “StS Programming,” “Select Discount,” etc.) will possibly need to be redone to match users’ desires, to account for more or less shelves.

Pressing <enter> at any of the “Shelf X, Position 1” prompt will cause the controller to enter the shelf calibration routine. The picker cup will move to the calibration position for the desired shelf. The <left> and <right> keys are used to move the cup left or right until the left wall of the picker cup is aligned with the left label holder for column 4. This is shown in Figure 3.2. **Note:** The cup will not move to the shelf position if the door is open or the cup is currently in motion. The shelf position will not be saved if the cup is currently in motion.

Pressing <enter> at the “Port X” prompt will cause the controller to enter the port calibration routine. The picker cup will move to a position above the delivery port. Use the <left> and <right> buttons to position the picker cup to the calibration position. When properly calibrated, the picker cup should be 1/32” (1 mm) from the port hook. (See “RVV NG Product Cup Manual Calibration” in SECTION 4: VENDER MAINTENANCE for a better description with illustration.)

**Note:** Once in the calibration menu, the controller will home the vend mechanism after the door is closed.

- **Test Diagnostics**

Pressing <enter> at the “Test Diagnostics” prompt will cause the controller to enter the diagnostic test routine. The display will show “Perimeter Test.” Use <up> or <down> to cycle through the available diagnostic tests. The door can be shut while in this part of the service menu. **Note:** If no activity is noticed after five minutes, the controller will exit the service menu.

*Note: If the DMC does not support the diagnostics command or the vender is currently busy and cannot respond to the diagnostics command, “Unavailable” will be displayed upon the initiation of the test. If the door is not in the correct state for this test to be carried out, either “DOOR MUST BE SHUT” or “DOOR MUST BE OPEN” will be displayed upon initiation of the test. If the test could not be carried out for whatever reason, the test must be reinitiated in order to try again. The system does not auto-detect that the problem has been fixed.*

1. **Perimeter Test**

Pressing <enter> at “Perimeter Test” will cause the vender to move the cup around the perimeter of the vending area once. This allows service personnel to observe if there are any obstructions around the perimeter of the vender that would inhibit vending. “Testing” will be displayed while this test is carried out. “Test Complete” will be displayed when the vender has completed this test. This is purely a visual test. Pressing <exit> will terminate the test. **Note:** The perimeter test will only start if the door is CLOSED.

2. **Delivery Test**

Pressing <enter> at “Delivery Test” will cause the vender to move the cup to the delivery position and attempt a delivery. If no product is dispensed, the vender will attempt to deliver two more times. This allows service personnel to observe if there are any obstructions around the delivery position of the vender that would inhibit vending. “Testing” will be displayed while this test is carried out. “Test Complete” will be displayed when the vender has completed this test. This is purely a visual test. Pressing <exit> will terminate the test. **Note:** The delivery test will only start if the door is CLOSED.

3. **Cup Test**

Pressing <enter> at “Cup Test” will cause the vender to actuate the plunger in the cup. This allows service personnel to observe if there are any problems with the cup plunger that would inhibit vending. “Testing” will be displayed while this test is carried out. “Test Complete” will be displayed when the vender has completed this test. This is purely a visual test. Pressing



## SECTION 3: Vender Programming

<exit> will terminate the test. *Note: The cup test will only start if the door is OPEN.*

### 4. Sensor Test

Pressing <enter> at “Sensor Test” will display in real time the settings of the sensors on the DMC. The following will be displayed:

```
MAG (0/1) Y (0/1) CS (0/1)
PDOOR (0/1) BIN (0/1)
```

- a. **MAG** corresponds to the Hall Effect home sensor that is used for finding the home position in the X-axis.
- b. **Y** corresponds to the Y-axis home sensor.
- c. **CS** corresponds to the cup sensor.
- d. **PDOOR** corresponds to the port door.
- e. **BIN** corresponds to the delivery bin.
- f. (0/1) corresponds to the sensor’s state: “0” = off, “1” = on.

This allows service personnel to observe if there are any problems with any of the sensors on the DMC. Pressing <exit> will terminate the test and return the display to “Sensor Test.” *Note: The sensor test can be performed with the door OPEN or CLOSED.*

### 5. Motor / Encoder Test

Pressing <enter> at “Motor / Encoder Test” will display in real time the encoder counts of the cup’s position. Pressing <up> will move the cup +450 encoder ticks, or +1 foot (+305 mm), in the Y-axis direction. Pressing <down> will move the cup -450 encoder ticks, or -1 foot (-305 mm), in the Y-axis direction. Pressing <right> will move the cup +300 encoder ticks, or +6 inches (+153 mm), in the X-axis direction. Pressing <left> will move the cup -300 encoder ticks, or -6 inches (-153 mm), in the X-axis direction. If the encoder’s count is off by more than +/-3 ticks from what is expected, there is a problem with the motor / encoder. Pressing <exit> will terminate the test, home the motors, and return the display to “Motor / Encoder Test.” *Note: The motor / encoder test can be performed with the door OPEN or CLOSED.*

### 6. Production Test

Pressing <enter> at “Production Test” will cause the vender to execute the production test. “Testing” will be displayed while this test is carried out. “Pass” will be displayed if the vender passes the test. Upon a failure in the test, the test will be terminated and a failure reason will be

displayed. This test only displays the last failure that caused the test to be terminated. Following is a list of potential failures.

1. “Failure X#” indicates a failure in the X-axis.
2. “Failure Y#” indicates a failure in the Y-axis.
3. “MAGNET RC” indicates a failure to find the magnet corresponding to the position for row “R” and cell “C.”
4. “EOT RC” indicates a failure to get to the end of travel of row “R” and cell “C.”
5. “SPEED” indicates a failure to adjust motor speed.
6. “SIDE S” indicates a failure in the perimeter test to move along side “S.”

This test allows manufacturing to run an all-over test of the machine settings. Pressing <exit> will terminate the test and return the display to “Production Test.” *Note: The production test will only start if the door is CLOSED.*

### 7. Multiple Home Test

Pressing <enter> at “Multiple Home Test” will cause the vender to home multiple times. “Testing” will be displayed while this test is carried out. “Pass” will be displayed if the vender passes the test. “Fail ##” will be displayed if the vender fails this test, where “##” represents a failure reason. This test allows service personnel to observe if there is any consistency in finding home. Pressing <exit> will terminate the test and return the display to “Multiple Home Test.” *Note: The production test will only start if the door is CLOSED.*

### • Test Display

Pressing <enter> at the “Test Display” prompt will cause the controller to enter the display test routine. This routine allows you to test the display. Upon entry into this routine, all segments of the display will light up. The test will continue for six seconds, and then the controller will return to the “Test Display” prompt. Press the <up> button to proceed to the last prompt in the test mode, “Test Relays.”

## SECTION 3: Vender Programming

### • Test Relays

Pressing <enter> at the “Test Relays” prompt will cause the controller to enter the relay test routine. This routine allows you to test the refrigeration, evaporator fan, heater, and light control relays. Upon entry into this routine, the display will show the state of the first relay, “Compressor X”, where X = “On” or “Off”. Pressing <up> or <down> will cycle through the available relay tests (listed below). Activation of <enter> at the displayed relay will toggle its state. **Note:** *To prevent equipment malfunctions, relay states should not be toggled more than once every 10 seconds.* If <exit> is pressed at anytime, the controller will return to the “Test Relays” prompt.

“Compressor”	- controls the compressor relay
“Fan”	- controls the evaporator fan relay
“Lighting”	- controls the sign front light relay
“Heater”	- controls the optional heater relay

### Set Prices

If <enter> is pressed at the “Set Prices” prompt, the controller will enter the selection price setting mode. If multiple prices are enabled, the controller will display “All Selections,” for a universal selection price. If <up> is pressed, the controller will cycle through the various price setting options (“All Selections,” “Shelf N,” or “Price Selection NN.”)

If single price mode is enabled, only a single price can be adjusted. In single price mode, “Single Price” will be displayed after pressing <enter> at the “Set Prices” prompt. If <enter> is pressed at “Single Price,” the display will show “XX.XX,” where the X’s represent the current single price setting. Pressing <up> or <down> will increase or decrease this price. When the desired price is displayed, press <enter> to save that price and return the controller to the “Single Price” prompt.

If <enter> is pressed while “All Selections” is displayed, the display will show “All Selections YY.YY,” where “YY.YY” is the current price for all selections in the machine. Use <up> or <down> to increase or decrease the price, then press <enter> to save it.

If <enter> is pressed while “Shelf N” is displayed (where “N” represents a shelf number), the display will show “YY.YY,” where “YY.YY” is the price for all of the products on that particular shelf. Use the <up> or <down> to increase or decrease the price, then press <enter> to save that price. Pressing <up> or <down> at the “Shelf N” prompt will cycle through all available shelf numbers.

If <enter> is pressed at the “Price Selection NN” prompt (where “N” represents a selection number), the display will show “YY.YY,” where “YY.YY” is the price for that particular selection. Use the <up> or <down> to increase or decrease the price, then press <enter> to save that price. Pressing <up> or <down> at the “Price Selection N” prompt will cycle through all available selection numbers. Press <exit> to return to the “Set Prices” prompt. From the “Set Prices” prompt, press <up> to continue to the next prompt, “Space to Sales.”

### Space to Sales

If <enter> is pressed at the “Space to Sales” prompt, the controller will enter the space to sales programming mode. The display will show “Option N”, where “N” is the current option selected, or “Custom StS” if a custom space to sales configuration is currently enabled. Using <up> or <down> will allow you to cycle through all the available space to sales options, as well as the “Custom StS” option. After setting space to sales and returning to the “Space to Sales” prompt, use <up> to proceed to the next prompt, “Set Package Size” (*software revisions 2.15 and higher*) or “Config Switches” (*prior to software revision 2.15*).

### Options

When one of the options (Option 1 through Option 3) is on the display, pressing <exit> will save that space to sales option. The display will show “Option N Saved,” then return to the “Space to Sales” prompt. The three available options are:

- Option 1: One for one (each individual selection number will only vend that column number);
- Option 2: By shelf (each selection number will vend all products on the same shelf in sequence); and
- Option 3: All selections tied together.

### Custom StS

If <enter> is pressed at the “Custom StS” prompt, you will have the opportunity to program a custom space to sales configuration. Upon entry into this routine, the display will show “Clear Settings?”. Pressing <exit> will return to the “Custom StS” prompt with no changes being made. Pressing <up> or <down> at the “Clear Settings?” prompt

## SECTION 3: Vender Programming

---

will display “Save Settings?” or “Selection NN,” followed by that selection’s current cell location assignment(s). If “Selection NN” is flashing and not followed by a cell location number, there are no cell locations assigned to selection NN. Using <up> or <down> will cycle through all the available selections and their associated cell assignments.

Pressing <enter> at the “Selection NN” prompt will allow the assignment of cell(s) or the entire shelf to selection NN. The display will show “Cell RC X” or “Entire Shelf R X,” where R is the shelf number, C is the number of the cell on shelf R, and X is the currently assigned state (1 = assigned or 0 = unassigned). Using <up> or <down> will allow you to cycle through the cells on shelf R. Pressing <enter> at when “Cell RC X” or “Entire Shelf R X” is displayed will cause X to flash. Press <up> or <down> to toggle X between “0” and “1.” When the desired setting is displayed, press <enter> to save the displayed status and return to the “Cell RC X” or “Entire Shelf R X” prompt, where X no longer flashes. If <exit> is pressed, the display will return to the “Selection NN” prompt. In order to save all settings, scroll to the “Save Settings” prompt and press <enter>.

**Notes:** Selection pricing must be aligned with the space-to-sales assignments.

*It is not possible to create a Custom StS assignment with products linked across shelves. If custom is entered after setting the system to use Option 3, the system reverts to Option 1 and starts the editing process.*

### Vend Evenly X

If <enter> is pressed at the “Vend Evenly X” prompt, you will be able to toggle between “Vend Evenly 0” (off) and “Vend Evenly 1” (on) by pressing <up> or <down>. If “Vend Evenly X” is set to “0,” the controller will vend in a FIFO (“first in, first out”) manner. FIFO vending corresponds to vending from one cell until it is completely sold out before vending from the next cell in the space-to-sales. If “Vend Evenly X” is set to “1,” the controller will vend evenly according to the space-to-sales settings. Vending evenly means it will vend only once from a cell before moving to the next cell in the space-to-sales. Pressing <enter> at this point will save the current setting. If <exit> is pressed during this editing process, the controller will not save the setting and will take you back to the “Vend Evenly X” prompt. Pressing <exit> at the “Vend Evenly X” prompt will take you back to the “Space to Sales” prompt.

### Set Package Size

*(Software revisions 2.15 and higher)*

If <enter> is pressed at the “Set Package Size” prompt, the controller will enter the package setting mode. This mode is used to adjust selections to vend certain small packages reliably. Using <up> or <down> will allow you to cycle through the various options for setting package size (“All RVV Select,” “Shelf N,” or “Cell NN”).

If <enter> is pressed while “All RVV Select” is displayed, the display will show “Package Size DEFAULT,” if all selections are set for default vending of packages, or “Package Size SMALL,” if all selections are set to vend small packages. Press <up> or <down> to change the displayed setting, then press <enter> to save it.

If <enter> is pressed while “Shelf N” is displayed (where “N” represents a shelf number), the display will show “Package Size DEFAULT,” if all selections on that shelf are set for default vending of packages, or “Package Size SMALL,” if all selections on that shelf are set to vend small packages. Press <up> or <down> to change the displayed setting, then press <enter> to save it. Pressing <up> or <down> at the “Shelf N” prompt will cycle through all available shelf numbers.

If <enter> is pressed while “Cell NN” is displayed (where “NN” represents a cell number), the display will show “Package Size DEFAULT,” if the cell is set for default vending of packages, or “Package Size SMALL,” if the cell is set to vend small packages. Press <up> or <down> to change the displayed setting, then press <enter> to save it. Pressing <up> or <down> at the “Cell NN” prompt will cycle through all available cell numbers. Press <exit> to return to the “Set Package Size” prompt. From the “Set Package Size” prompt, press <up> to continue to the next prompt, “Config Switches.”

## SECTION 3: Vender Programming

### Configurations

If <enter> is pressed at the “Configurations” prompt, the controller will enter the machine configuration mode by displaying “Cn – Switch Description X”, where the “n” is the configuration switch number and “X” is the current status (1 = enabled or 0 = disabled). Using <up> or <down> will allow you to cycle through all available configuration options. If <exit> is pressed anytime during this operation the controller will return to the “Configurations” prompt. From the “Configurations” prompt, use <up> to proceed to the next prompt, “Revert to Defaults.”

If <enter> is pressed the display will flash “X” (the current status). Pressing <up> or <down> will cause the flashing status to toggle between “0” (disabled) and “1” (enabled). When the desired status is displayed, pressing <enter> will save that status and return to the “Cn – Switch Description X” display.

The following information describes the various machine configuration options.

- **C1 - Multi Price**

This option is used to toggle between the single-price and multi-price modes. In the single-price mode, the price of selection 1 will be used for all selections. In the multi-price mode, each selection can be set to a different price.

If X = 0, single pricing is used.  
If X = 1, multi-pricing is used.

- **C2 - Additional Menu**

This option is used to enable the Additional Menu, which contains several more mode options than available in the standard service menu.

If X = 0, the Additional Menu will not appear.  
If X = 1, the Additional Menu will appear.

- **C4 - Summary MIS**

This option is used to turn on the display of the total machine sales and total machine cash values in the open-door mode.

If X = 0, only errors will be displayed when the door is open.  
If X = 1, sales and cash totals will be displayed and “Errors” or “No Errors” will replace the error codes when the door is open.

- **C5 - Door Switch Reset MIS**

This option is used to allow the door switch to reset all resettable MIS (resettable cash and sales counts, etc.).

If X = 0, all resettable MIS registers are reset only when the “CF” command is received from the hand held device (HHC).

If X = 1, all resettable MIS registers are reset when the door switch is sensed as open and at least one of the resettable MIS registers has been read (i.e., individual cash and sales counts).

- **C6 - Cheat Mode**

This option is used to prevent vending with insufficient change to pay back correct change after a purchase. If disabled and the correct change cannot be paid back, the vend is aborted and the deposited credit is returned if possible.

If X = 0, the cheat mode is disabled.  
If X = 1, the cheat mode is enabled.

- **C7 - Bill Acceptance**

This option is used to allow higher order bills to be accepted without the risk of cheating the customer. If enabled, a bill is not accepted unless the controller verifies that it has enough change to cover the bill’s value plus any accumulated credit.

If X = 0, high order bill acceptance is disabled.  
If X = 1, high order bill acceptance is enabled.

- **C8 - Force Vend**

This option prevents the machine from becoming a change maker. When this mode is enabled, escrow of coins is allowed until any of the following three events occurs: 1. Any bill is inserted into the bill acceptor; 2. Any “cash box” coin is inserted into the changer; or 3. The maximum vend price is reached. Once any of these conditions are met, any accumulated credit must be used toward a vend attempt, and coins will not be dispensed for credit in response to an escrow request. If a sold out selection, or if a valid selection that becomes sold out, is made this option will be over-ridden and an escrow will be honored.

If X = 0, forced vend attempt is disabled.  
If X = 1, forced vend attempt is enabled.

*Note that force vend has no effect on the card reader; once a card is inserted it can always be returned to the customer via the escrow lever on the changer or return button on the card reader.*

## SECTION 3: Vender Programming

- **C9 - Multi-Vend**

This option will allow multiple purchases without re-entering coins. If enabled, instead of immediately returning the change after a vend, the credit will remain on the display to be used for another selection. An escrow request will be honored at any time. This option will take precedence over the force vend option after the first vend has been completed.

If X = 0, multi-vend is disabled.

If X = 1, multi-vend is enabled.

### Conflicting Options

*In order to avoid conflicts between options and potential cheating of customers, it is recommended that the following rule be followed:*

*If Cheat Mode is disabled (C6 = 0), then both Bill Acceptance Checking and Bill Escrow should be enabled (C7 & C10 = 1). This is the only way to ensure the customer will never be cheated.*

- **C10 - Bill Escrow**

This option will allow escrowing of bills. If enabled, and the current bill value inserted takes the accumulated credit over the maximum price, the bill will be held in the escrow position. If the rule is disabled, bills will always go to the cash box.

If X = 0, Bill Escrow is disabled (bill sent to cashbox).

If X = 1, Bill Escrow is enabled.

- **C16 - Rdr Lvl Enb**

This option allows cashless devices (such as card readers) to use MDB Level 2 communication protocol. When enabled, card revaluing is supported.

If X = 0, MDB Level 2 is disabled for cashless devices (no card revaluing).

If X = 1, MDB Level 2 is enabled for cashless devices (i.e., card revaluing is enabled).

### Revert to Defaults

If <enter> is pressed at the “Revert to Defaults” prompt, “Are you sure?” will be displayed. If <exit> is pressed at this prompt, no settings will be cleared and the display will return to the “Revert to Defaults” prompt. If <enter> is pressed, all system configurations will be returned to their default values (factory settings), and the display will show “VMC Re-initialized” for approximately three seconds. The display will then return to the “Revert to Defaults” prompt. Space to Sales, Prices, Configurations, Language, and time-assigned features will all be reset to defaults. DEX accounting fields, real-time clock settings, and error conditions will not be reset. Use <up> to proceed to the next prompt, “Exact Change Only.”

### Exact Change Only

The “Exact Change Only” menu configures the value that the controller will use to control the “EXACT CHANGE ONLY” indicator. If the controller determines that it cannot return the exact amount of this value and every value in increments of the least coin tube value less than it, then the indicator must be turned on. For example, given a least tube coin of a nickel and an ECO value of \$0.25, the system must be able to pay back 5, 10, 15, 20, and 25 cents.

If <enter> is pressed at the “Exact Change Only” prompt, the current exact change value will be displayed. Pressing <up> or <down> will adjust the currently displayed exact change value up or down. Pressing <enter> will save the currently displayed exact change value and return to the “Exact Change Only” prompt. Pressing <exit> at any point in the procedure will return to the “Exact Change Only” prompt without saving any changes. Use <up> to proceed to the next prompt, “Coin Pay Out.”

### Coin Pay Out

If <enter> is pressed at the “Coin Pay Out” prompt the controller will enter the coin payout mode by displaying the lowest coin value that can be paid out. Pressing <up> will increase the display to show the next highest coin value, pressing <down> will decrease the display to show the next lowest coin value or wrap around. Pressing <enter> when a particular coin value is displayed will pay out the displayed coin type at half-second intervals until the button is released. All coins dispensed in this mode are counted in the MIS tube counts and the manual dispense mode counters. Pressing <exit> while a coin value is displayed will return the controller to the “Coin Pay Out” prompt. Use <up> to proceed to the next prompt, “Tube Fill.”

## SECTION 3: Vender Programming

### Tube / Stack Fill

If <enter> is pressed at the “Tube / Stack Fill” prompt the controller will enter the coin tube and bill stack fill mode. In this mode, you are allowed to deposit any coin that is routed to a tube or any bill that can be stacked. This provides total accountability. The tube or stack inventory level for the deposited coin or bill will be displayed after the coin or bill is accepted. If a tube full or stack full status is detected, that coin or bill will no longer be accepted. During this entire operation, MIS tube counts and manual fill mode counters will be updated accordingly. If <exit> is pressed at any time during this operation, the controller will return to the “Tube / Stack Fill” prompt. Use <up> to proceed to the next prompt, “Recycler Pay Out” (67241-11 and higher) or “Set Discounts” (67241-10 and lower). **Note:** *Software revisions 67241-10 and lower will show only “Tube Fill” and will not work with the validator stacker.*

### Recycler Pay Out

*(software revisions 67241-11 and higher)*

If <enter> is pressed at the “Recycler Pay Out” prompt the controller will enter the bill payout mode by displaying the lowest bill value that can be paid out. Pressing <up> will increase the display to show the next highest bill value, if any; pressing <down> will decrease the display to show the next lowest bill value or wrap around. Pressing <enter> when a particular bill value is displayed will pay out the displayed bill type. All bills dispensed in this mode are counted in the MIS manual dispense mode counters. Pressing <exit> while a bill value is displayed will return the controller to the “Recycler Pay Out” prompt. Use <up> to proceed to the next prompt, “Set Discounts.”

### Set Discounts

If <enter> is pressed at the “Set Discounts” prompt, the controller will enter the discount control mode. Using <up> or <down>, the user can cycle through the various discount control settings (“Enable Discounting,” “Start Time,” “Stop Time,” “Discount Selections,” and “Discount Amount”). If <exit> is pressed, the controller will return to the “Set Discounts” prompt. Use <up> to proceed to the next prompts, “Selection Blocking 1,” “Selection Blocking 2,” and “Selection Blocking 3.”

- **Enable Discounting**

Upon first entry into “Set Discounts”, the controller will display “Enable Discounting X”. If <enter> is pressed at “Enable Discounts X”, “X” will begin flashing indicating that it can be edited. If X = 1, discounts will be enabled. This means that active selections will be discounted by the programmed discount amount during the programmed time blocks. Discounted vend prices of zero or less may be allowed, but no credit will ever be given in return. If X = 0, discounting will be disabled. Pressing <up> or <down> will allow the user to toggle “X” between “1” and “0”. Pressing <enter> will save the displayed setting and return you to the non-editable “Enable Discounting” prompt. Use <up> to proceed to the next prompt, “Start Time.”

- **Start Time**

If <enter> is pressed at the “Start Time” prompt, the controller will enter the start discounting time setting routine. Upon entry into this routine, the display will show the first of the two start time setting modes, “Start Day” or “Start Hour.” Pressing <up> or <down> will cycle between the two. Pressing <exit> at this point will return to the “Start Time” prompt without saving any changes.

If <enter> is pressed at the “Start Day” prompt, the controller will enter the day of the week setting routine. The display will show “YY X”, where “YY” is the day of the week (Monday, Tuesday, Wednesday, Thursday, Friday, Saturday, Sunday, or Every Day) and “X” is either “1” or “0”. Pressing <up> or <down> will cycle through the days of the week. If <enter> is pressed at the “YY X” prompt, “X” will flash, indicating that it can be changed. Pressing <up> or <down> will toggle “X” between “1” (enabled) and “0” (disabled). Pressing <enter> again will save the displayed setting and return you to the non-flashing “YY X” prompt. Pressing <exit> will return to the “Start Day” prompt.

## SECTION 3: Vender Programming

---

If <enter> is pressed at the “Start Hour” prompt, the controller will enter the start time setting routine. The display will show the current four-digit hour and minute setting, in 24-hour format. The hour setting will be flashing to indicate that it can be modified. Pressing <up> or <down> will increase or decrease the hour. Pressing <enter> will stop the hour from flashing and cause the minutes to blink indicating they can be modified. Pressing <up> or <down> will increase or decrease the minutes value. Pressing <enter> again will save the displayed setting and return you to the “Start Hour” prompt. Pressing <exit> while in editing mode will return to the “Start Hour” prompt without saving changes. Use <up> to proceed to the next prompt, “Stop Time.”

- **Stop Time**

If <enter> is pressed at the “Stop Time” prompt, the controller will enter the stop discounting time setting routine. Upon entry into this routine, the display will show the first of the two stop time setting modes, “Stop Day” or “Stop Hour.” Pressing <up> or <down> will cycle between the two. Pressing <exit> at this point will return to the “Stop Time” prompt without saving any changes.

If <enter> is pressed at the “Stop Day” prompt, the controller will enter the day of the week setting routine. The display will show “YY X”, where “YY” is the day of the week (Monday, Tuesday, Wednesday, Thursday, Friday, Saturday, Sunday, or Every Day) and “X” is either “1” or “0”. Pressing <up> or <down> will cycle through the days of the week. If <enter> is pressed at the “YY X” prompt, “X” will flash, indicating that it can be changed. Pressing <up> or <down> will toggle “X” between “1” (enabled) and “0” (disabled). Pressing <enter> again will save the displayed setting and return you to the non-flashing “YY X” prompt. Pressing <exit> will return to the “Stop Day” prompt.

If <enter> is pressed at the “Stop Hour” prompt, the controller will enter the stop time setting routine. The display will show the current four-digit hour and minute setting, in 24-hour format. The hour setting will be flashing to indicate that it can be modified. Pressing <up> or <down> will increase or decrease the hour. Pressing <enter> will stop the hour from flashing and cause the minutes to blink indicating they can be modified. Pressing <up> or <down> will increase or decrease the minutes value. Pressing <enter> again will save the displayed setting and return you to the “Stop Hour” prompt. Pressing <exit> while in editing mode will return to the “Stop Hour” prompt without saving changes. Use <up> to proceed to the next prompt, “Discount Selections.”

- **Discount Selections**

If <enter> is pressed at the “Discount Selections” prompt, the controller will display “Selection N X”, where “N” represents the selection number and “X” indicates whether that selection will be discounted or not. Using <up> or <down> will allow you to cycle through each individual selection. If <enter> is pressed at “Selection N X”, the display will flash “X” (discount status) for the displayed selection. Then pressing <up> or <down> will toggle “X” between “1” (enabled) or “0” (disabled). When the desired setting is on the display, pressing <enter> will save that setting and return to the selection level, where the “X” no longer flashes. If the “All Selections X” is set and saved, all the selections will be set at once. Use <exit> to return to the “Discount Selections” prompt. Use <up> to proceed to the next prompt, “Discount Amount.”

- **Discount Amount**

If <enter> is pressed at the “Discount Amount” prompt, the controller will display current four digit discount amount (00.00 – 99.95). Using <up> or <down> will increase or decrease this amount in increments of the least coin tube value. Pressing <enter> will save the setting and return to the “Discount Amount” prompt. Pressing <exit> will return you to the “Discount Amount” prompt without saving any changes. From the “Discount Amount” prompt, use <exit> to return to the “Set Discounts” prompt. (*Note: If the discount amount is greater than the sales price for a given selection, the selection will free-vend.*)

## SECTION 3: Vender Programming

Selection Blocking 1 /  
Selection Blocking 2 /  
Selection Blocking 3

If <enter> is pressed at the “Selection Blocking X” prompt (where X = 1, 2, or 3), the controller will enter the selection blocking control mode. Using <up> or <down>, you can cycle through the various selection blocking timer settings (“Enable Blocking,” “Start Time,” “Stop Time,” and “Blocked Selections”). If <exit> is pressed, the controller will return to the “Selection Blocking X” prompt. Use <up> to proceed to the next prompt, “Set Time / Date.”

- **Enable Blocking**

Upon first entry into “Selection Blocking X”, the controller will display “Enable Blocking X”. If <enter> is pressed at “Enable Blocking X”, “X” will begin to flash, indicating that it can be edited. If X = 1, selection blocking will be enabled. This means that active programmed selections will not be allowed to vend during programmed time blocks and a “No Sale Until xx:xx” message will be displayed. The “xx:xx” will be replaced with the time vends will be allowed again (12 hour format if using “NA” or “OFF” daylight savings time settings; 24 hour format otherwise). If X = 0, selection blocking will be disabled. Pressing <up> or <down> will allow the user to toggle “X” between “1” and “0”. Pressing <enter> will save the displayed setting and return you to the non-editable “Enable Blocking” prompt. Use <up> to proceed to the next prompt, “Start Time.”

- **Start Time**

If <enter> is pressed at the “Start Time” prompt, the controller will enter the start selection blocking time setting routing. Upon entry into this routine, the display will show the first of the two start time setting modes, “Start Day” or “Start Hour.” Pressing <up> or <down> will cycle between the two. Pressing <exit> at this point will return to the “Start Time” prompt without saving any changes. Use <up> to proceed to the next prompt, “Stop Time.”

If <enter> is pressed at the “Start Day” prompt, the controller will enter the day of the week setting routine. The display will show “YY X”, where “YY” is the day of the week (Monday, Tuesday, Wednesday, Thursday, Friday, Saturday, Sunday, or Every Day) and “X” is either “1” or “0.” Pressing <up> or <down> will cycle through the days of the week. If <enter> is pressed at the “YY X” prompt, “X” will flash indicating that it can be changed. Pressing <up> or <down> will toggle “X” between “1” (enabled) and “0” (disabled). Pressing <enter> again will save the displayed setting and return you to the non-flashing “YY X” prompt. Pressing <exit> will return to the “Start Day” prompt.

If <enter> is pressed at the “Start Hour” prompt, the controller will enter the start time setting routine. The display will show the current four-digit hour and minute setting, in 24-hour format. The hour setting will be flashing to indicate that it can be modified. Pressing <up> or <down> will increase or decrease the hour. Pressing <enter> will stop the hour from flashing and cause the minutes to flash, indicating they can be modified. Pressing <up> or <down> will increase or decrease the minutes value. Pressing <enter> again will save the displayed setting and return you to the “Start Hour” prompt. Pressing <exit> while in editing mode will return to the “Start Hour” prompt without saving changes.

- **Stop Time**

If <enter> is pressed at the “Stop Time” prompt, the controller will enter the stop selection blocking time setting routing. Upon entry into this routine, the display will show the first of the two stop time setting modes, “Stop Day” or “Stop Hour. Pressing <up> or <down> will cycle between the two. Pressing <exit> at this point will return the controller to the “Stop Time” prompt without saving any changes. Use <up> to proceed to the next prompt, “Blocked Selections.”



## SECTION 3: Vender Programming

If <enter> is pressed at the “Stop Day” prompt, the controller will enter the day of the week setting routine. The display will show “YY X”, where “YY” is the day of the week (Monday, Tuesday, Wednesday, Thursday, Friday, Saturday, Sunday, or Every Day) and “X” is either “1” or “0”. Pressing <up> or <down> will cycle through the days of the week. If <enter> is pressed at the “YY X” prompt, “X” will flash, indicating that it can be changed. Pressing <up> or <down> will toggle “X” between “1” (enabled) and “0” (disabled). Pressing <enter> again will save the displayed setting and return you to the non-flashing “YY X” prompt. Pressing <exit> will return to the “Stop Day” prompt.

If <enter> is pressed at the “Stop Hour” prompt, the controller will enter the stop time setting routine. The display will show the current four-digit hour and minute setting, in 24-hour format. The hour setting will be flashing to indicate that it can be modified. Pressing <up> or <down> will increase or decrease the hour. Pressing <enter> will stop the hour from flashing and cause the minutes to flash, indicating they can be modified. Pressing <up> or <down> will increase or decrease the minutes value. Pressing <enter> again will save the displayed setting and return you to the “Stop Hour” prompt. Pressing <exit> while in editing mode will return the controller to the “Stop Hour” prompt without saving changes.

- **Blocked Selections**

If <enter> is pressed at the “Blocked Selections” prompt, the controller will display “All Selections X,” where “X” indicates whether all selections will be blocked or not. Using <up> or <down> will allow you to cycle through each individual selection. If <enter> is pressed at “Block Selection N X,” the display will flash “X” (block status) for the displayed selection. Pressing <up> or <down> will toggle “X” between “1” (enabled) or “0” (disabled). When the desired setting is on the display, pressing <enter> will save the setting and return to the selection level, where the block status no longer flashes. If the “All Selections X” is set and saved, all the selections will be set at once. Use <exit> to return to the “Blocked Selections” prompt. From the “Blocked Selections” prompt, use <exit> to return to the “Selection Blocking X” prompt.

### Set Time / Date

If <enter> is pressed at the “Set Time / Date” prompt, the controller will enter the current time setting mode by displaying “Year.” Using <up> or <down> will allow you to cycle through all available time setting options. If <exit> is pressed anytime during this operation, the controller will return to the “Set Time / Date” prompt. Use <up> to proceed to the next prompt, “Refrigeration.”

- **Year**

If <enter> is pressed at the “Year” prompt, the current year setting is displayed and will be flashing. Pressing <up> or <down> at this point will increase or decrease the year setting. Pressing <enter> will save the displayed year setting and return you to the “YEAR” prompt. Use <up> to proceed to the next prompt, “Month.”

- **Month**

If <enter> is pressed at the “Month” prompt, the current month setting is displayed and will be flashing. Pressing <up> or <down> at this point will increase or decrease the month setting. Pressing <enter> will save the displayed month setting and return you to the “Month” prompt. Use <up> to proceed to the next prompt, “Date.”

- **Date**

If <enter> is pressed at the “Date” prompt, the current two digit date-of-the-month setting (01-31) is displayed. Pressing <up> or <down> at this point will increase or decrease this number. If <enter> is pressed, the currently displayed date is saved and the controller will return to the “Date” prompt. Use <up> to proceed to the next prompt, “Hour.”

- **Hour**

If <enter> is pressed at the “Hour” prompt, the current time is displayed in a 24-hour format. The left two digits of the display show the current hour setting; the right two digits show the current minutes. The hour setting will be flashing. Pressing <up> or <down> at this point will increase or decrease the hour setting. If <enter> is pressed, the minute setting will flash. Pressing <up> or <down> at this point will increase or decrease the minutes setting. Pressing <enter> again will save the displayed hour and minutes setting and return you to the “Hour” prompt. Pressing <exit> while in editing mode will return you to the “Hour” prompt without saving changes. Use <up> to proceed to the next prompt, “Daylight Savings.”

## SECTION 3: Vender Programming

- **Daylight Savings**

If <enter> is pressed at the “Daylight Savings” prompt, the display will show the current daylight saving time code. Using <up> or <down> will rotate through the available options listed below. Pressing <enter> when the desired saving time code is displayed will save that code and return you to the “Daylight Savings” prompt. Pressing <exit> at any time in this options list will return you to the “Daylight Savings” prompt without saving any changes. Use <up> to proceed to the next prompt, “Display Time.”

“OFF”:	No daylight savings time changes made.
“AUS”:	Australian rules Set forward 1 hour at 1:00 a.m. on first Sunday in October Set back 1 hour at 1:00 a.m. on last Sunday in March
“EU”:	European rules Set forward 1 hour at 1:00 a.m. on last Sunday in March Set back 1 hour at 1:00 a.m. on last Sunday in October
“NA”:	North American rules Set forward 1 hour at 2:00 a.m. on first Sunday in April Set back 1 hour at 2:00 a.m. on last Sunday in October

- **Display Time**

If <enter> is pressed at the “Display Time X” prompt, the display will show “Display Time X”, where “X” will be flashing. If X = 0, this indicates that the current time will not be displayed with the POS message in sales mode. If X = 1, the time will be displayed in sales mode. Using <up> or <down> will toggle the value of “X.” If <enter> is pressed at this point the currently displayed value of “X” will be saved, and you will be returned to the non-editable “Display Time” prompt. Use <exit> to return to the “Set Time / Date” prompt.

### Refrigeration

If <enter> is pressed at the “Refrigeration” prompt the controller will enter the refrigeration control mode. Using <up> or <down>, you can rotate through the various refrigeration control settings (“Conserve Energy,” “Start Time,” “Stop Time,” “Degrees,” “Set Point,” “Storage Temperature,” “Display Temp,” “Health Safety,” and “Defrost Interval”). If <exit> is pressed, the controller will return to the “Refrigeration” prompt. Press <up> to proceed to the next prompt, “Lighting Control.”

- **Conserve Energy**

Upon first entry into “Refrigeration,” the controller will display “Conserve Energy X”. If <enter> is pressed at “Conserve Energy X,” “X” will begin to flash, indicating that it can be edited. If X = 1, the energy conservation control will be enabled. This means the cabinet temperature will be allowed to rise to the programmed storage level during programmed time blocks. If X = 0, the energy conservation mode will be disabled, and the machine will function as normal. Pressing <up> or <down> will allow you to toggle “X” between 1 (enabled) and 0 (disabled). Pressing <enter> will save the displayed setting and return you to the non-editable “Conserve Energy” prompt. Use <up> to proceed to the next prompt, “Start Time.” (*Note: “Conserve Energy” is overridden when “Health Safety” is active. See “Health Safety,” next page.*)

- **Start Time**

If <enter> is pressed at the “Start Time” prompt, the controller will enter the start energy conservation time setting routine. Upon entry into this routine, the display will show the first of the two start time setting modes, “Start Day” or “Start Hour.” Pressing <up> or <down> will cycle between the two. Pressing <exit> at this point will return to the “Start Time” prompt without saving any changes. Use <up> to proceed to the next prompt, “Stop Time.”

If <enter> is pressed at the “Start Day” prompt, the controller will enter the day of the week setting routine. The display will show “YY X”, where “YY” is the day of the week (Monday, Tuesday, Wednesday, Thursday, Friday, Saturday, Sunday, or Every Day) and “X” is either “1” or “0.” Pressing <up> or <down> will cycle through the days of the week. If <enter> is pressed at the “YY X” prompt, “X” will flash indicating that it can be changed. Pressing <up> or <down> will toggle “X” between “1” (enabled) and “0” (disabled). Pressing <enter> again will save the displayed setting and return you to the non-flashing “YY X” prompt. Pressing <exit> will return to the “Start Day” prompt.

## SECTION 3: Vender Programming

If <enter> is pressed at the “Start Hour” prompt, the controller will enter the start time setting routine. The display will show the current four-digit hour and minute setting, in 24-hour format. The hour setting will be flashing to indicate that it can be modified. Pressing <up> or <down> will increase or decrease the hour. Pressing <enter> will stop the hour from flashing and cause the minutes to flash, indicating they can be modified. Pressing <up> or <down> will increase or decrease the minutes value. Pressing <enter> again will save the displayed setting and return you to the “Start Hour” prompt. Pressing <exit> while in editing mode will return to the “Start Hour” prompt without saving changes.

- **Stop Time**

If <enter> is pressed at the “Stop Time” prompt, the controller will enter the stop energy conservation time setting routine. Upon entry into this routine, the display will show the first of the two stop time setting modes, “Stop Day” or “Stop Hour. Pressing <up> or <down> will cycle between the two. Pressing <exit> at this point will return the controller to the “Stop Time” prompt without saving any changes. Use <up> to proceed to the next prompt, “Degrees.”

If <enter> is pressed at the “Stop Day” prompt, the controller will enter the day of the week setting routine. The display will show “YY X”, where “YY” is the day of the week (Monday, Tuesday, Wednesday, Thursday, Friday, Saturday, Sunday, or Every Day) and “X” is either “1” or “0”. Pressing <up> or <down> will cycle through the days of the week. If <enter> is pressed at the “YY X” prompt, “X” will flash, indicating that it can be changed. Pressing <up> or <down> will toggle “X” between “1” (enabled) and “0” (disabled). Pressing <enter> again will save the displayed setting and return you to the non-flashing “YY X” prompt. Pressing <exit> will return to the “Stop Day” prompt.

If <enter> is pressed at the “Stop Hour” prompt, the controller will enter the stop time setting routine. The display will show the current four-digit hour and minute setting, in 24-hour format. The hour setting will be flashing to indicate that it can be modified. Pressing <up> or <down> will increase or decrease

the hour. Pressing <enter> will stop the hour from flashing and cause the minutes to flash, indicating they can be modified. Pressing <up> or <down> will increase or decrease the minutes value. Pressing <enter> again will save the displayed setting and return you to the “Stop Hour” prompt. Pressing <exit> while in editing mode will return the controller to the “Stop Hour” prompt without saving changes. From “Stop Time,” pressing <up> will proceed you to the next prompt, “Degrees.”

- **Degrees**

If <enter> is pressed at the “Degrees X” prompt, the controller will display “Degrees X,” where “X” will be flashing. If X = F, the controller is currently in Fahrenheit mode; if X = C, the controller is currently in Celsius mode. Pressing <up> or <down> will toggle “X” between “F” and “C.” Pressing <enter> at this point will save the displayed temperature mode and return you to the “Degrees X” prompt. Pressing <exit> will return you to the “Degrees X” prompt without saving changes. Use <up> to proceed to the next prompt, “Set Point.”

- **Set Point**

The set point default is 36° F (2.0° C). If <enter> is pressed at the “Set Point” prompt, the controller will display the current set point temperature setting “xx F” or “xx.x C,” depending on the “Degrees” setting. Using <up> or <down> will increase or decrease the number by 1° F (0.5° C). Pressing <enter> will save the set point and return you to the “Set Point” prompt. Pressing <exit> will return to the “Set Point” prompt without saving changes. From “Set Point,” press <up> to proceed to the next prompt, “Storage Temperature.”

- **Storage Temperature**

The default storage temperature will be 45° F (7.0° C). If <enter> is pressed at the “Storage Temperature” prompt, the controller will display the current storage temperature setting “xx F” or “xx.x C,” depending on the “Degrees” setting. Using <up> or <down> will increase or decrease the number by 1° F (0.5° C), over the range of 32° F to 75° F (0° C to 24° C). Pressing <enter> will save the storage temperature and return you to the “Storage Temperature” prompt. Pressing <exit> will return you to the “Storage Temperature” prompt without saving changes. From “Storage Temperature,” press <up> to proceed to the next prompt, “Display Temp.”

## SECTION 3: Vender Programming

- **Display Temp**

If <enter> is pressed at the “Display Temp” prompt, the controller will display “Display Temp X,” where “X” will be flashing. If X = 1, the controller will display the temperature immediately following the POS. If X = 0, the controller will not display the temperature. Pressing <up> or <down> will toggle “X” between “1” and “0.” Pressing <enter> will save the currently displayed setting and return you to the “Display Temp” prompt. Pressing <exit> will return you to the “Display Temp” prompt without saving changes. From “Display Temp,” press <exit> to return to the “Refrigeration” prompt. From “Display Temp,” press <up> to proceed to the next prompt, “Health Safety.”

- **Health Safety**

If <enter> is pressed at the “Health Safety X” prompt, the controller will display “Health Safety X,” where X will be flashing. If X = 1 (for yes), the controller will enable the health safety timer used in conjunction with an additional temperature sensor. If X = 0 (for no), the controller will disable the health safety timer. Pressing <up> or <down> will toggle the X between “1” and “0”. Press <enter> to save the currently displayed setting and return to the “Health Safety X” prompt. Press <exit> to return to the “Health Safety X” prompt without saving changes. Health Safety will not be enabled if the cabinet temperature sensor is defective or not installed. From “Health Safety,” press <up> to proceed to the next prompt, “Defrost Interval.”

- **Defrost Interval**

The default defrost interval is 3 hours. This setting is used to determine how often the machine will go into defrost mode. If <enter> is pressed at the “Defrost Interval” prompt, the controller will display current defrost interval setting, “XX Hours,” where XX is the interval setting in hours. Using <up> or <down> will increase or decrease the interval setting by one hour, from 3 to 24. Pressing <enter> will save the currently displayed setting and return the user to the “Defrost Interval” prompt. Pressing <exit> will return to the “Defrost Interval” prompt without saving changes.

### Lighting Control

If <enter> is pressed at the “Lighting Control” prompt, the controller will enter the lighting control mode. Using <up> or <down>, you can cycle through the various lighting control settings (“Enable Control,” “Start Time,” and “Stop Time”). If <exit> is pressed, the controller will return to the “Lighting Control” prompt. From this prompt, press <up> to proceed to the next prompt, “Preview Password.”

- **Enable Control**

Upon first entry into “Lighting Control,” the controller will display “Enable Control X”. If <enter> is pressed at “Enable Control X,” “X” will begin to flash, indicating that it can be edited. If X = 1, lighting control will be enabled. If X = 0, lighting control will be disabled. This means that the lighting panels of the vender will be turned off during the programmed time blocks. Pressing <up> or <down> will allow the user to toggle “X” between “1” (enabled) and “0” (disabled). Pressing <enter> will save the displayed setting and return you to the non-editable “Enable Control” prompt. From the “Enable Control” prompt, use <up> to proceed to the next prompt, “Start Time.”

- **Start Time**

If <enter> is pressed at the “Start Time” prompt, the controller will enter the start lighting control time setting routine. Upon entry into this routine, the display will show the first of the two start time setting modes, “Start Day.” Pressing <up> or <down> will cycle between “Start Day” and “Start Hour.” Pressing <exit> at this point will return you to the “Start Time” prompt without saving any changes. Use <up> to proceed to the next prompt, “Stop Time.”

If <enter> is pressed at the “Start Day” prompt, the controller will enter the day of the week setting routine. The display will show “YY X”, where “YY” is the day of the week (Monday, Tuesday, Wednesday, Thursday, Friday, Saturday, Sunday, or Every Day) and “X” is either “1” or “0”. Pressing <up> or <down> will cycle through the days of the week. If <enter> is pressed at the “YY X” prompt, “X” will flash, indicating that it can be changed. Pressing <up> or <down> will toggle “X” between “1” (enabled) and “0” (disabled). Pressing <enter> again will save the displayed setting and return you to the non-flashing “YY X” prompt. Pressing <exit> will return the controller to the “Start Day” prompt.

If <enter> is pressed at the “Start Hour” prompt, the controller will enter the start time setting routine.

## SECTION 3: Vender Programming

The display will show the current four-digit hour and minute setting in 24-hour format. The hour setting will be flashing to indicate that it can be modified. Pressing <up> or <down> will increase or decrease the hour. Pressing <enter> will stop the hour from flashing and cause the minutes to flash, indicating they can be modified. Pressing <up> or <down> will increase or decrease the minutes value. Pressing <enter> again will save the displayed setting and return you to the “Start Hour” prompt. Pressing <exit> while in editing mode will return the controller to the “Start Hour” prompt without saving changes.

- **Stop Time**

If <enter> is pressed at the “Stop Time” prompt, the controller will enter the stop lighting control time setting routine. Upon entry into this routine, the display will show the first of the two stop time setting modes, “Stop Day” and “Stop Hour.” Pressing <up> or <down> will cycle between the two. Pressing <exit> at this point will return to the “Stop Time” prompt without saving any changes. From this prompt, press <exit> to return to the “Lighting Control” prompt.

If <enter> is pressed at the “Stop Day” prompt, the controller will enter the day of the week setting routine. The display will show “YY X”, where “YY” is the day of the week (Monday, Tuesday, Wednesday, Thursday, Friday, Saturday, Sunday, or Every Day) and “X” is either “1” or “0”. Pressing <up> or <down> will cycle through the days of the week. If <enter> is pressed at the “YY X” prompt, “X” will flash, indicating that it can be changed. Pressing <up> or <down> will toggle “X” between “1” (enabled) and “0” (disabled). Pressing <enter> again will save the displayed setting and return you to the non-flashing “YY X” prompt. Pressing <exit> will return you to the “Stop Day” prompt.

If <enter> is pressed at the “Stop Hour” prompt, the controller will enter the stop time setting routine. The display will show the current four-digit hour and minute setting in 24-hour format. The hour setting will be flashing to indicate that it can be modified. Pressing <up> or <down> will increase or decrease the hour. Pressing <enter> will stop the hour from flashing and cause the minutes to flash, indicating they can be modified. Pressing <up> or <down> will increase or decrease the minutes value. Pressing <enter> again will save the displayed setting and return you to the “Stop Hour” prompt. Pressing <exit> while in editing mode will return you to the “Stop Hour” prompt without saving changes.

### Preview Password

If <enter> is pressed at the “Preview Password” prompt, the controller will display the current password for the external menu. The first digit of the number will be flashing. Pressing <up> or <down> will adjust the currently flashing digit up or down. Pressing <enter> will save the currently flashing digit and cause the next digit of the password to begin flashing. All digits may be modified in this manner. Pressing <exit> at any point in the procedure will save the currently displayed password and return you to the “Preview Password” prompt. From the “Preview Password” prompt, use <up> to proceed to the next prompt, “Set Language.”

### Set Language

If <enter> is pressed at the “Set Language” prompt, the controller will display the current language setting. Pressing <up> or <down> will sequence through the available language settings: English, French, German, Italian, Portuguese, Spanish, Slovenian, Finnish, Norwegian, and Custom. Pressing <enter> at any point in the procedure will save the currently displayed language setting and return you to the “Set Language” prompt. Custom language is present only if custom language has been uploaded using DEX. From the “Set Language” prompt, use <up> to proceed to the next prompt, “Manual Over-Rides.”

### Manual Over Rides

If the controller is equipped with a key switch, it can be used to override some of the settings stored for normal operation of the vendor. The key switch can be programmed to control one or several features simultaneously. If a feature is enabled in this menu, that feature will override normal machine operation when the switch is activated.

If <enter> is pressed at the “Manual Over Rides” prompt the controller will enter the override configuration setting mode by displaying “Free Vend”. Using <up> or <down> will allow you to cycle through all available override configuration options. If <exit> is pressed at any time during this operation, the controller will return to the “Manual Over Rides” prompt. From the “Manual Over Rides” prompt, press <up> to proceed to the final prompt, “Return to Sales.”

The following options can be selected in the override selection level:

- **Free Vend**

If <enter> is pressed at the “Free Vend X” prompt, where “X” is the current status (either “1” or “0”), the

## SECTION 3: Vender Programming

display will flash the current status. Pressing <up> or <down> will cause the flashing status to toggle between “1” and “0.” When the desired status is displayed, pressing <enter> will save that status and return you to the “Free Vend X” display (status no longer flashing). If “Free Vend” is enabled, “Free” will be displayed immediately after the POS message.

If X = 0, free vend will be disabled when the key switch is activated.

If X = 1, free vend will be enabled when the key switch is activated.

*Note: All free vends will increase free vend MIS counters (VA3).*

- **No Vend**

If <enter> is pressed at the “No Vend X” prompt, where “X” is the current status (either “1” or “0”), the display will flash the current status. Pressing <up> or <down> will cause the flashing status to toggle between “1” and “0.” When the desired status is displayed, pressing <enter> will save that status and return you to the “No Vend X” display (status no longer flashing). If “No Vend” is enabled, no selections will be allowed to vend and a “No Sale” message will be displayed.

If X = 0, no vend will be disabled when the key switch is activated.

If X = 1, no vend will be enabled when the key switch is activated.

*Note: If both “Free Vend” and “No Vend” are enabled, “No Vend” will be given priority (no vending will be allowed).*

- **Selection Blocking**

If <enter> is pressed at the “Selection Blocking X” prompt, where “X” is the current status (either “1” or “0”), the display will flash the current status. Pressing <up> or <down> will cause the flashing status to toggle between “1” and “0.” When the desired status is displayed, pressing <enter> will save that status and return to the “Selection Blocking X” display (status no longer flashing).

If X = 0, selection blocking will be disabled when the key switch is activated.

If X = 1, selection blocking will be enabled when the key switch is activated.

*Note: “Selection Blocking” is used in conjunction with “Selection Blocking X” programming menus.*

- **Discounting**

If <enter> is pressed at the “Discounting X” prompt, where “X” is the current status (either “1” or “0”), the display will flash the current status. Pressing <up> or <down> will cause the flashing status to toggle between “1” and “0.” When the desired status is displayed, pressing <enter> will save that status and return you to the “Discounting X” display (status no longer flashing).

If X = 0, discounting will be disabled when the key switch is activated.

If X = 1, discounting will be enabled when the key switch is activated.

- **Lighting**

If <enter> is pressed at the “Lighting X” prompt, where “X” is the current status (either “1” or “0”), the display will flash the current status. Pressing <up> or <down> will cause the flashing status to toggle between “1” and “0.” When the desired status is displayed, pressing <enter> will save that status and return you to the “Lighting X” display (status no longer flashing).

If X = 0, lighting control will be disabled when the key switch is activated.

If X = 1, lighting control will be enabled when the key switch is activated.

- **Refrigeration**

If <enter> is pressed at the “Refrigeration X” prompt, where “X” is the current status (either “1” or “0”), the display will flash the current status. Pressing <up> or <down> will cause the flashing status to toggle between “1” and “0.” When the desired status is displayed, pressing <enter> will save that status and return you to the “Refrigeration X” display (status no longer flashing).

If X = 0, refrigeration control will be disabled when the key switch is activated.

If X = 1, refrigeration control will be enabled when the key switch is activated.

### Return to Sales

If <enter> is pressed at the “Return to Sales” prompt, the controller will return to the idle condition of the sales mode, unless there is established credit. If credit exists, the credit amount will be displayed after returning to sales mode.

## SECTION 3: Vender Programming

---

### External Menu

Access the External Menu by entering your 4-digit password when the main door is closed (see “Preview Password” in the “Internal [Service] Menu” section).

*Note:* In the External Menu, the <clear> button will have no function. Sales counters can not be reset and error codes can not be cleared in the External Menu.

#### Sales Counters

If the external preview password is correctly entered, the display will show “Sales Counters.” If <enter> is pressed at the “Sales Counters” prompt, the controller will enter the non-resettable sale count display mode displaying “Sales Total XXX,” where the X’s represent the number of all paid vends over the life of the vender’s control board. Using <up> or <down> will cycle through each selection as “Sales Sel N XXX,” where “N” represents the appropriate selection number and the X’s represent the number of vends for that selection. If <exit> is pressed anytime during this operation, the controller will return to the “Sales Counters” prompt. Press the <up> button to proceed to the next prompt, “Error Codes.”

#### Error Codes

If <enter> is pressed at the “Error Codes” prompt, the controller will enter the error display mode. If no errors have occurred since the last error reset, the display will show “None.” If an error has been detected since the last error reset, the display will show the first summary error code that has occurred, such as “Vend,” which would indicate a vend error. Pressing <up> or <down> will allow you to cycle through all of the summary error codes that are present. Pressing <enter> at the displayed summary error code will allow you to view the detailed error codes beneath the summary error heading. Pressing <up> or <down> at this point will allow you to cycle through all of the detailed error codes that are present beneath the summary error code. If the <exit> button is pressed at anytime during this operation, the controller will return to the “Error Codes” prompt. Press the <up> button to proceed to the next prompt, “Return to Sales.”

*For further details on reading error codes, see “Error Codes” in the “Internal [Service] Menu” section.*

#### Return to Sales

If <enter> is pressed at the “Return to Sales” prompt, the controller will return to the sales mode.

## SECTION 4: Vender Maintenance

---

# Vender Maintenance

## What to Clean

**CAUTION:** *Electrical and electronic components should NEVER be subjected to water.*

**Belts:** The belts should always be kept clean and free of debris to ensure efficient operation, as well as to extend the life of the belts.

**Cells:** Make sure the cells are free of dirt, syrup, and debris. Build-up of foreign material, especially syrup from broken or leaking packages, can cause the cell to stick and adversely affect the cell's performance. Use warm soapy water or other food grade cleaning agents to maintain a clean smooth surface. Also make sure that the cells are level and seated properly in the tracks that they slide into.

**Condenser and Evaporator Coils:** For efficient operation, the condenser and evaporator coils must be kept clear of any dirt or foreign materials. Clean dirt and debris from the condenser and evaporator coils with a small light-bristled brush, vacuum cleaner, or compressed air. This will help to ensure an extended unit life.

**VMC and DMC:** The vender's control boards (VMC and DMC) should always be enclosed by their covers to protect them. Routine cleaning is not necessary but, if desired, the boards' area may be blown out with compressed air.

**Delivery Bin:** Make sure that the delivery bin remains clean and free of any debris or other objects that may block the optic sensors. Bottles sometimes have a tendency to lose their labels, which may be left in the delivery bin. If objects are left in the bin and the sensors are blocked, the board will assume there is a package in the bin and will not deliver product to the bin.

**Elevator Arm and Cup Tracks:** The elevator arm and cup assemblies travel in aluminum tracks that guide these components. Make sure that these tracks are kept clean and free from foreign material such as dirt, syrup, or other debris. Use a wet cloth to wipe these tracks clean. Avoid using any type of silicone or lubricant, as they may tend to collect dirt and will adversely affect performance.

**Product Cup:** The cup floor should be kept clean and free of syrup.

## Lubrication

**Latch Strike Nut:** *TriTeq locks:* The latch strike nut **should not** be lubricated. *T-handle locks:* The latch strike nut **should** be lubricated.

**Refrigeration Unit:** The refrigeration unit is a sealed system that does not require any lubrication. Also, the condenser and evaporator fan motors do not require any lubrication.

## Preventive Maintenance

**Vender Leveling:** Make sure that the vender is level when placed on site. If the vender is not properly leveled it can begin to accumulate standing water, which over a period of time may begin to freeze and will eventually freeze the evaporator. Another problem that may occur from an unlevelled vender will be improper vending, which would include but not be limited to product not vending from cell, product vending slowly from cell, product not being delivered to the delivery bin, or product jamming.

**Vender Support Leg:** The RVV is equipped with a vender support leg. This leg is similar to the leveling legs but is longer and is located in the bottom door hinge. It is very critical that after the vender is placed on location and is leveled that this support leg is brought down even with the ground, floor, or whatever surface the vender is placed on. If the support leg is not making contact with the ground surface there is a possibility of the vender tipping over when the door is opened, possibly resulting in **broken bones, dismemberment, or even death.**

**Lighting System:** The lighting system contains extremely high voltage (upwards of 600 volts), and power should always be disconnected when working with or around this portion of the vender. Light bulbs should be replaced whenever one or more of the bulb ends are blackened or discolored, or when the lights are flickering or are not lit, and it has been determined that the ballast is good. Replace these bulbs as soon as it is determined they are bad. If it is decided not to use the lighting system, the ballast **MUST** be unplugged. **DO NOT** remove the bulbs and leave the ballast plugged in. Doing so can cause the ballast to generate a very high amount of electrical noise, which can cause problems with or permanently damage electronic components.



## SECTION 4: Vender Maintenance

### RVV NG Product Cup Manual Calibration

1. With the main door open, enter the service mode, enter the test mode, and enter the calibration menu.
2. Press <enter>, the key in the password but do not press <enter>. The display should show "Shelf 1 Position 1."
3. Close the vender's main door and wait for the homing routine to finish.
4. Press <enter>. The cup should go to the first shelf.
5. Align the left edge of the cup with the right edge of the seventh card insert feature. (See Figure 4.1.)
6. Press <enter>. The display should momentarily show "Saved."
7. Press <enter> to go to the second shelf.
8. Repeat steps 5 and 6 for the remaining shelves.
9. After the last shelf has been calibrated, "Port X" should appear on the display. Open the main door, and press <enter>. The cup should move to the port location.
10. Align the outermost face of the cup with the outer edge of the port hook, with 1/32" (1 mm) gap. (See Figure 4.2.)
11. Bend back tab on cup trip arm so arm is approximately 1/32" (1 mm) away from the door wall.
12. Press <enter>. The display should momentarily show "Saved."
13. Exit out of calibration mode, and close the vender's main door.

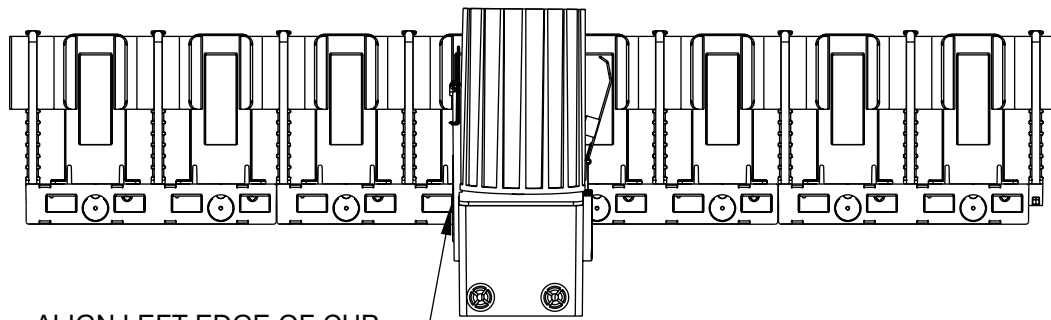

ALIGN LEFT EDGE OF CUP WITH THE RIGHT EDGE OF THE SEVENTH CARD INSERT AREA AS COUNTING FROM THE LEFT OF THE SHELF.

Figure 4.1

GAP BETWEEN DOOR FACE AND CUP TRIP ARM TO BE APPROXIMATELY 1/32" (1 mm).

GAP BETWEEN OUTERMOST FACE OF CUP AND EDGE OF PORT HOOK TO BE APPROXIMATELY 1/32" (1 mm).

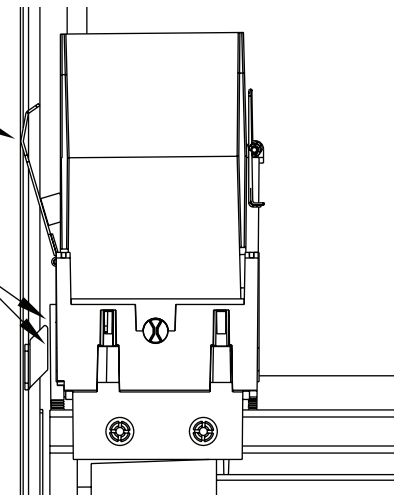

Figure 4.2

## SECTION 5: Troubleshooting

# Troubleshooting

The RVV is equipped with a self-diagnostic feature to aid in the repair and maintenance of the vender. When servicing the vender, pay close attention to the digital display. When the vender door is opened, the display will begin showing any error codes that are stored in memory. If there are no errors, the display will show “No Errors.”

To enter the Service Mode, press and release the blue Service Mode Button located on the VMC board. The display will show “Errors Were Detected” if there are recorded errors. If <enter> is pressed at the “Errors Were Detected” prompt, the controller will enter the error display mode. The display will show the first error summary code that has occurred.

If <enter> is pressed, the controller will display the detailed error for the summary code. The <up> and <down> buttons will cycle through any remaining error detail codes. If <exit> is pressed while displaying any *detailed* code, the controller will return to the summary code. If <exit> is pressed while displaying any *summary* code, the controller will return to the code level (“No Errors” or “Errors Were Detected”).

**NOTE:** When troubleshooting errors with peripherals, the appropriate peripheral service manual(s) should also be consulted for further tests and corrective actions.

## Troubleshooting by Error Codes

Error Type	Detailed Error Code	Test Procedure	Corrective Action
Control System	Door Switch - Indicates that one or both of the door switches has been open for more than one hour.	Check both the upper and lower vender door switches to see if either one is sticking or miswired. If nothing is found at the door switch, check the connector for the switch cable running to the VMC board. Also check to see if the harness has broken or pinched wires.	Replace the door switches if defective. Repair or replace the switch harness to the VMC board.
	RAM Checksum - Indicates that the machine setup information has been corrupted.	No test available.	If error shows up frequently, contact Royal Vendors' Customer Support.
	DC Under Voltage - Indicates that the voltage from the power supply was under 20 VDC for more than 30 seconds.		Check for shorts or crimped / smashed wires in the vender. Replace any damaged cables. If no damage cables can be found and repaired, then replace the power supply.
	DC Over Voltage - Indicates that the voltage from the power supply was over 45 VDC for more than 30 seconds.		Replace the power supply.
	System Scale Factor - Indicates that one of the credit peripherals has introduced an incompatible scaling factor.	Check the connections of the changer harness. Make sure changer is plugged up and working.	Make connections to the harness or replace the changer.

## SECTION 5: Troubleshooting

Error Type	Detailed Error Code	Test Procedure	Corrective Action
Changer	Changer Comm - Indicates no changer communications for more than 2 seconds.	Check serial changer and MDB harnesses.	Replace any harnessing found to be defective.
	Tube Sense - Indicates a tube sensor error.	Check changer tubes for blockage.	Clear tube blockage if found. If no blockage, replace changer.
	Tube Jam XX - Indicates a tube jam error for coin type XX.	Check changer tubes and payback for blockage	Clear blockage if found. If no blockage found, replace changer.
	Changer ROM - Indicates a changer ROM checksum error.	Unplug vender and wait at least 5 seconds; replug machine. Manually clear error	If error does not clear, replace the changer.
	Excessive Escrow - Indicates more than 255 escrow attempts since the last coin was accepted.	Check escrow lever and associated mechanisms.	If vender returns to Sales mode from open door mode without input, replace changer / acceptor.
		Go to open door mode and wait for 30 seconds. Manually clear the error.	If vender stays in the open door mode and the manually cleared error does not reoccur, system may be okay.
	Coin Jam - Indicates a coin jam.	Check changer / acceptor for jammed coins or other obstructions.	In no obstructions are found, replace the coin acceptor.
	Low Acceptance - Indicates a low acceptance rate (more than 20% of the last 255 coins were slugs).	Check changer / acceptor for obstruction or dirt.	If no obstructions are apparent and the acceptance appears to be okay, this may be an indication of cheating attempts.
		Drop coins in tubes and payback for blockage.	If no obstructions are apparent and coins do not accept or acceptance rate is poor, replace the changer / acceptor.
	Disconnected Acceptor - Indicates an unplugged coin acceptor.		Plug in the coin acceptor.
Misrouted Coin - Indicates a coin had been improperly routed.			
Bill Validator	Bill Val Comm - Indicates no bill validator.	Check serial changer and MDB harnessing.	Replace MDB harness.
	Bill Stacker Full - Indicates a full bill stacker.	Ensure bill cash box is empty, and that the cash box is properly closed and in place.	If cash box appears to be okay, replace the bill acceptor.
	Bill Motor - Indicates a defective bill acceptor motor.	No test available.	Replace bill acceptor.
	Bill Jam - Indicates a bill jam error.	Check bill acceptor for obstruction or dirt.	If no obstructions are apparent, replace the bill acceptor.
	Bill Val ROM - Indicates a bill acceptor ROM check sum error.	Unplug machine and wait at least 5 seconds, then replug machine. Manually clear error.	If error does not clear, replace the bill acceptor.
	Open Cash Box - Indicates an open cash box.	Check that bill cash box is closed and in correct position.	If cash box appears to be okay, replace the bill acceptor.
	Bill Sensor - Indicates a bill sensor error.	Check bill acceptor for obstruction or dirt.	If no obstructions are apparent, replace the bill acceptor.
Card Reader	Card Reader Comm - Indicates no card reader communications for more than 5 minutes.		
	Card Reader Error XY - Indicates that a particular type of card reader malfunction occurred where "XY" indicates the error type.	No test available.	Refer to card reader manual for corrective action.

## SECTION 5: Troubleshooting

Error Type	Detailed Error Code	Test Procedure	Corrective Action
Vend Mechanism	Delivery System - Indicates that there is a generic vend mechanism error.		
	Cup Sensor - Indicates that the cup product detect transmitter, receiver, or the oscillator on the cup board has malfunctioned.	Check continuity in the cup transmitter and cup receiver harnesses.	Replace the transmitter and / or receiver harness if faulty. Otherwise, replace the cup board, transmitter board, and receiver board.
	Critical Mech - Indicates that the DMC home sensor has malfunctioned.		
	USD Comm - Indicates that the DMC-USD is no longer online.		
	Delivery Port Sense - Indicates that the DMC in reporting a port sense error.	Check to make sure there are no obstructions blocking the LED's in the port.	Remove and items blocking the port sensors.
		Check the connections between the port transmitter and receiver boards.	Replace the port detection cable, if connections were found to be correct.
			If replacing the cable does not correct the problem, replace the port receiver and transmitter boards.
	Delivery Port Door - Indicates that the DMC is reporting a port door error.	Check to make sure the port door is not sticking in a closed position.	Clean port door slides, or replace port door.
		Check to make sure that the connector to the delivery door switch is connected.	Reconnect the connector to the switch.
		Check the delivery door switch.	Replace the delivery door switch if defective.
Check the Delivery Door Power / Signal harness and the Port / Delivery Door harness for damage.		Replace any harnessing found to be defective.	
Space to Sales	Unassigned Cell XX - Indicates that cell XX is unassigned.		
Refrigeration (continued on next page)	Temperature Sensor - Indicates an unplugged temperature sensor error.	Check the temperature sensor connection at the control board (VMC) to make sure it is plugged in. Check that it is wired properly and the pins are making contact.	If the sensor is unplugged, replug it. If it is miswired, replace the temperature sensor. If the connections are bad, attempt to repair them or replace sensor.
	Too Cold - Indicates a temperature 10° F (5.5° C) below the compressor cut-out setting. (continued on next page)	1. Check the refrigeration unit before opening the vender's main door to see if it is running.	If upon unplugging the white wires the unit stops:
		2. Open the main door to see if the unit cuts off.	1. Check the temperature sensor's reading.
		3. Make sure the vender's door switches are working properly.	2. Check Set Point settings.
		4. Unplug the green wire plugged into the refrigeration relay.	3. Check the green and blue wires for shorts from the control board.
		4. If upon unplugging the green wire the unit still runs, unplug one of the two white wires. If the unit stops, replace the refrigeration relay. If optional heater relay kit is not installed, one may be required.	

## SECTION 5: Troubleshooting

Error Type	Detailed Error Code	Test Procedure	Corrective Action
Refrigeration (continued from previous page)	Too Cold - Indicates a temperature 10° F (5.5° C) below the compressor cut-out setting. <i>(continued from previous page)</i>		5. If heater kit is installed and heater does not turn on (heater relay does not click upon energizing in heater relay test mode), check the two white wires from the board to the heater relay for 24 VDC. Check the other wire for continuity between the control board and the relay. If voltage is okay, replace the relay; otherwise, replace control board.
	Too Hot - Indicates a temperature 10° F (5.5° C) above the compressor cut-in setting.	Proceed with normal refrigeration troubleshooting.	
	Compressor - Indicates that the cooling system is not heating at 1° F (0.5° C) per hour or better while on.		
	Heater - Indicates that the cooling system is not heating at 1° F (0.5° C) per hour or better while on.		
	No Pulldown - Indicates an inability to reach the set point temperature.		
	Health Safety Failed - Indicates that the health safety temperature has been violated.		

## Troubleshooting by Symptom

Error / Problem	Test Procedure / Possible Cause	Corrective Action
Vender does not power up after door is closed.	Make sure there are no obstructions holding the door open.	Check to make sure the case holder is folded and placed correctly, and remove any obstructions.
		On venders with TriTeq locks, make sure the electronic door lock is securely latched back into the door.
	Open the door and manually close both door switches.	If the unit does not power up, check to make sure the door switch harness is connected properly to the VMC board. If it is, then replace the switches. If the unit still does not power up, replace the switch harness.
Door cannot close completely.	Make sure there are no obstructions holding the door open.	Make sure the vender is plugged in and that the fuse in the vender is not blown.
		Check to make sure the case holder is folded and placed correctly, and remove any obstructions.
Vender displays "Door Locked Open" on vender with TriTeq lock.	Make sure there are no obstructions holding the door open.	On venders with TriTeq locks, make sure the electronic door lock is securely latched back into the door.
		Check to make sure the case holder is folded and placed correctly, and remove any obstructions.
		Make sure the electronic lock is securely latched back into the door.
		Adjust the bolt on the TriTeq locking bolt 1/2 turn and close the door again. Repeat again for 1/2 turn of the locking bolt until the vender powers up.

# SECTION 5: Troubleshooting

Error / Problem	Possible Cause / Corrective Action
<p>Display showing REMOVE PRODUCT.</p>	<p>Check to see whether the port bin is hanging open or is flush to the door. If the port bin is hanging open, reset the security latch on the port bin. If it doesn't reset, check the white port nuts (bushings) on either side of the port assembly. If they are broken, replace them.</p>
	<p>Check the harnessing to the emitter and detector boards located in the product bin. Check the harnessing on both control boards, at position P4 on the DMC board (5 VDC on the black and brown wires) and at position P11 on the VMC board (5 VDC on the red and black wires). If no voltage is found, replace that particular board.</p>
	<p>Check the wiring and the mating of the port slide switch and the linkage arm.</p>
	<p>Check for coins or debris under or on top of the emitter and detector boards in the product bin. Remove and reseat the emitter and detector boards ensuring that the metal plate the emitter board sits on is properly inserted into the two metal tabs under the port assembly.</p>
	<p>If all the above is good, replace the detector board first. Test the vend mechanism. If the error still exists, replace the emitter board.</p>
<p>Product cup not finding the home position. Cup continually moving to the extreme left and right walls. Home Sensor error.</p>	<p>Make sure that the X-home magnet bracket mounted under the bottom product shelf is in the proper position. The magnet should be facing you and should be flush with the front edge of the bottom shelf.</p>
	<p>Ensure that the gantry arm is parallel with the bottom of the main door.</p>
	<p>Remove the product cup floor, and check the wiring from the Hall Effect sensor to position P4 on the logic board in the cup.</p>
	<p>Check for 5 VDC on the red and black wires at position P4 on the cup logic board. If no voltage is found, check for 5 VDC on the green and black wires at position P1 on the cup logic board. If voltage is found, replace the cup board. If no voltage is found at P1, check for 5 VDC on the green and black wires at position P3 on the DMC board. If voltage is found, replace the harness; if voltage is not found, replace the DMC board.</p>
	<p>Secondary search pattern note: After attempting to home the first time, the cup will enter a secondary search pattern. During this, the cup will move back and forth between two or three cells on the bottom shelf and move the gantry arm up about 1/8" (3 mm) after each pass. If the vender enters this search sequence, allow it to finish and either find home or go to OUT OF SERVICE before opening the door and performing the troubleshooting steps above.</p>
<p>Product cup finds the home position and then attempts to do a delivery test. Product cup does not complete the delivery test, attempts three times, stops short of delivery door or bangs against port side wall, then goes to OUT OF SERVICE.</p>	<p>Check the micro-switch at the top of the port slide. Ensure that when the port slide is opened, the switch is not stuck shut. If the switch sticks, repair or replace it.</p>
	<p>Check calibration on PORT X. Refer to Section 4: Vender Maintenance for calibration instructions.</p>
	<p>If calibration does not hold, refer to "X-motor troubleshooting," below.</p>
<p>Product cup not finding the home position. Cup continually moving up and down about 6 inches (15 cm). HOME SENSOR error.</p>	<p>Make sure the elevator gantry is level and the gantry is all the way down on the vertical home switch.</p>
	<p>Check the wiring to the vertical home switch.</p>
	<p>Check the wiring on the black and red wires at position P1 on the DMC board.</p>
	<p>If all the above is good, replace the vertical home switch. If this does not fix the issue, replace the DMC board.</p>
<p>Product cup does not find shelf, does not pull product, or pulls out product only half-way. <i>(continued on next page)</i></p>	<p>Make sure the shelves are pushed in and seated properly in the shelf runners.</p>
	<p>Check to make sure the door is properly closed and the lights turn on.</p>
	<p>Check to make sure the shelf is flush with the cabinet and is level.</p>
	<p>Remove the fuse from the bottom of the door and drive the product cup left and right using the X-belt. Make sure there are no binds and the cup drives smoothly all the way from the far right to the far left.</p>
	<p>Check the calibration. Refer to Section 4: Vender Maintenance for calibration instructions.</p>
	<p>Check to make sure the X-magnet is located in the left-hand corner of the odd numbered cell (behind the price label) that the product cup is not finding.</p>

## SECTION 5: Troubleshooting

Error / Problem	Possible Cause / Corrective Action
Product cup does not find shelf, does not pull product, or pulls out product only half-way. <i>(continued from previous page)</i>	Check for condensation under the X-motor encoder cap. If condensation is found, refer to "X-motor troubleshooting," below.
	Check to make sure the back wheels of the product cup are locked into the back rail (closest to the glass) and are properly seated in the cup.
	If all the above does not help, replace the product cup assembly.
Product cup moves left and right in 2" (5 cm) increments and then up about 8" (20 cm), then back down.	Check the connections at the X-motor.
	Check the connections at position P2 on the DMC board.
	If all the above is good, replace the X-motor.
Product cup begins its homing sequence but fails to move up or down after finding home. Cup then moves to the left of the door and the display shows OUT OF SERVICE.	Check the connections at the Y-motor.
	Check the connections at position P1 on the DMC board.
	If all the above is good, replace the Y-motor.
Display shows OUT OF SERVICE after the door is shut and the product cup performs its homing routine. Cup does find the home position, then shows OUT OF SERVICE. CUP SENSOR error shown.	Make sure there is nothing blocking the optic sensors in the product cup.
	Remove the product cup floor and check the connections from the emitter and detector boards to the logic board in the cup (positions P6 and P7).
	Remove the covers to the emitter and detector boards to make sure the two boards are aligned properly and the lenses are seated properly (black lens on the left and clear lens on the right). Check the connections at the emitter and detector boards.
	If all the above does not help, replace the product cup assembly.
Product cup goes to the correct selections but fails to pick up a product and the cup returns to the home position. The display shows PLEASE RE-SELECT.	Check calibration.
	Use the cup test in the Diagnostics menu to test the plunger function.
	Refer to error / problem "Product cup...half-way," shown above.
	If all the above is good, replace the product cup assembly.
Gantry will not stay level.	With the fuse removed, re-level the gantry arm. Drive the gantry arm up by pulling on the port-side Y-belt. If you hear a clicking noise (the belt slipping), adjust the tension on the Y-belts and re-test.
	Check the top idler assembly and Y-motor for loose pulleys.
X-motor troubleshooting.	Carefully remove the rubber X-motor encoder cap and check for condensation. If condensation is found, allow the encoder to dry, and search for the cause of the condensation.
	Check the connections at the X-motor and at position P2 on the DMC board.
	Check the X-belt for proper tension and the X-motor pulley for slippage.
	Use the motor / encoder test in the Diagnostics menu to check the function of the X-motor.
	If after replacing the X-motor the problems still persist, replace the X-motor harness.
Cup is able to open delivery port door, but the cup will not tilt to deliver product.	Check calibration on PORT X. Refer to the service and parts manual for calibration instructions.
	While in X-port calibration, adjust the cup trim arm so that it catches the trip bracket above the delivery port.
Cell attempts to multi-vend to the cup.	For clear products, check the cup optic sensors and lenses.
	For all other products: a. Check the shelf for proper seating. b. Check the Hall Effect sensor on the drive motor. c. Check for 5 VDC on the red and black wires at position P5 on the cup logic board.

# SECTION 5: Troubleshooting

## Test Diagnostics Routines Troubleshooting

The Test Diagnostics routines are designed to aid in troubleshooting the vender. To access these routines, follow these steps:

1. Press the blue mode button on the VMC (Vender Main Controller) board.
2. Press <up> until the display shows `Test Modes`, then press <enter>.
3. Press <up> until the display shows `Test Diagnostics`, then press <enter>. The display will show `Perimeter Test`. The vender is now in the diagnostic test routine. To scroll through the subroutines (`Perimeter Test`, `Delivery Test`, `Cup Test`, `Sensor Test`, `Motor / Encoder Test`), press <up>.

*Note: If the DMC does not support the diagnostics command or the vender is currently busy and cannot respond to the diagnostics command, "Unavailable" will be displayed upon the initiation of the test. If the door is not in the correct state for this test to be carried out, either "DOOR MUST BE SHUT" or "DOOR MUST BE OPEN" will be displayed upon initiation of the test. If the test could not be carried out for any reason, the test must be reinitiated in order to try again. The system does not auto-detect that the problem has been fixed.*

### Contents

- I. Perimeter Test
- II. Delivery Test
- III. Cup Test
- IV. Sensor Test
- V. Motor / Encoder Test
- VI. Production Test
- VIII. Multiple Home Test

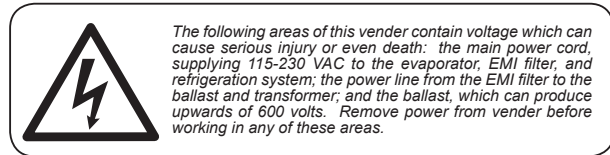

### I. Perimeter Test

Pressing <enter> at `Perimeter Test` will cause the vender to move the cup around the perimeter of the vending area once. The Perimeter Test allows service personnel to observe if there are any obstructions around the perimeter of the vender that would inhibit vending. `Testing` will be displayed while this test is carried out. `Test Complete` will be displayed when the vender has completed this test. Pressing <exit> will terminate the test. **Note:** *The perimeter test will only start if the door is CLOSED.*

### II. Delivery Test

Pressing <enter> at `Delivery Test` will cause the vender to move the cup to the delivery position and attempt a delivery. If no product is dispensed, the vender will attempt to deliver two more times. This allows service personnel to observe if there are any obstructions around the delivery position of the vender that would inhibit vending. `Testing` will be displayed while this test is carried out. `Test Complete` will be displayed when the vender has completed this test. Pressing <exit> will terminate the test. **Note:** *The delivery test will only start if the door is CLOSED.*

#### **Possible problems:**

- A. Cup attempts to do a delivery test three times, never completes test, then stops short of delivery door or bangs against side wall and shows `OUT OF SERVICE` on the display
- B. Cup opens delivery port door, but the cup will not tilt to deliver product



## SECTION 5: Troubleshooting

- A. Cup attempts to do a delivery test three times, never completes test, then stops short of delivery door or bangs against side wall and shows OUT OF SERVICE on the display.**
1. Check the port slide switch, at the top of the port slide. (Refer to Figure 5.1.) Ensure that when the port slide is opened, the switch is not stuck shut. If the switch sticks, repair or replace it.
  2. Check calibration on Port X. Refer Section 3: Vender Programming for calibration instructions.
- B. Cup opens delivery port door, but the cup will not tilt to deliver product.**
1. Check calibration on Port X. Refer Section 3: Vender Programming for calibration instructions.
  2. While in X-port calibration, adjust the cup trip arm so that it catches the trip bracket above the delivery port. (Refer to Figures 5.2 and 5.3.)

**FIGURE 5.1.**

Port slide switch

Ensure that the switch is not stuck shut when the port door is opened. The switch should click upon opening and closing it.

Port slide switch

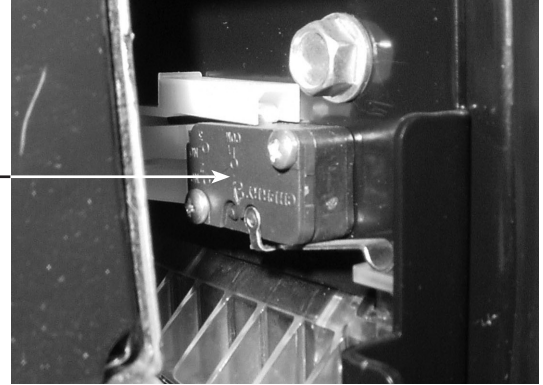

**FIGURE 5.2 and 5.3.**

Trip bracket and cup trip arm

Adjust the arm so that it catches the trip bracket (hook) when the cup goes down to deliver product.

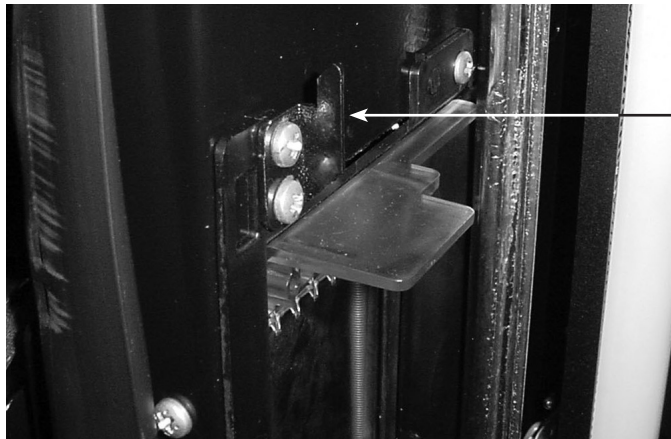

Trip bracket (difficult to see in this photograph)  
The trip bracket is a hook located above the port door.

Cup trip arm

The cup trip arm should engage the trip bracket. If it does not, adjust the trip arm by bending it slightly.

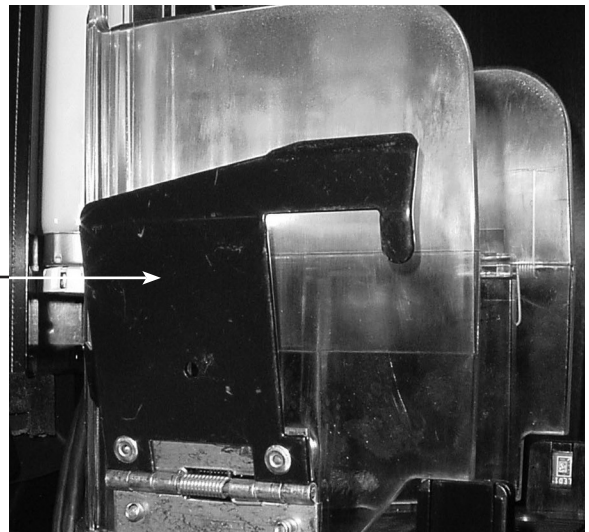

# SECTION 5: Troubleshooting

## III. Cup Test

Pressing <enter> at **CUP Test** will cause the vender to actuate the plunger in the cup. This test allows service personnel to observe if there are any problems with the cup plunger that would inhibit vending. **TESTING** will be displayed while this test is carried out. **TEST COMPLETE** will be displayed when the vender has completed this test. Pressing <exit> will terminate the test. **Note:** *The delivery test will only start if the door is OPEN.*

### Possible problems:

- A. Plunger does not extend out from cup
- B. Plunger does not spin

#### A. Plunger does not extend out from cup. (Refer to Figure 5.4.)

1. Remove the top of the cup, and check the harness connection at pinout P3 on the cup logic board. (Refer to Figure 5.5.) Make sure there are no loose wires and the connection is tight.
2. Using an ohmmeter, check for continuity on all wires in the harnessing from the DMC to the cup logic board. If **any** wire fails, replace the harness. If **all** wires pass, replace the cup logic board. If the problem persists, replace the plunger motor. (Refer to Figure 5.6.)

**FIGURE 5.4.**

Location of cup plunger  
Use *Cup Test* to actuate the plunger:

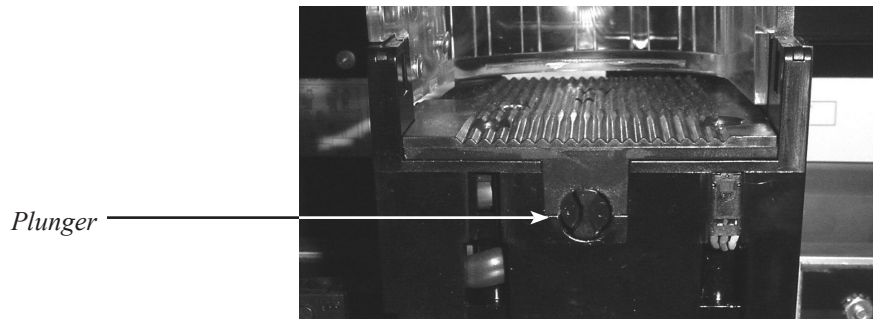

**FIGURE 5.5.**

Location of position P3  
Make sure the harness at the connection on the logic board is tight, with no wires loose, backed out, etc.

Position P3

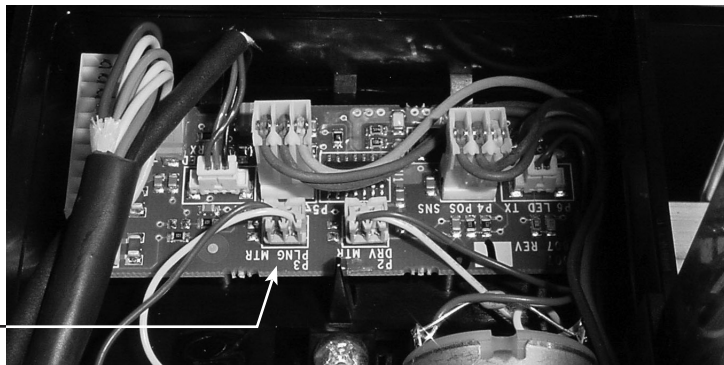

**FIGURE 5.6.**

View of inside of cup from above

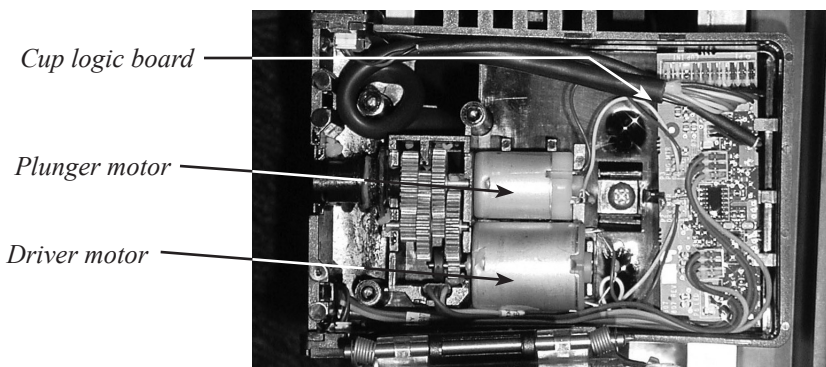

## SECTION 5: Troubleshooting

### B. Plunger does not spin. (Refer to Figure 5.4.)

1. Remove the top of the cup, and check the harness connection at pinout P2 on the cup logic board. (Refer to Figure 5.7.) Make sure there are no loose wires and the connection is tight.
2. Ensure that all the gears inside the cup are seated properly and are in their correct positions. (Refer to Figure 5.8.)
3. Using an ohmmeter, check for continuity on all wires in the harnessing from the DMC to the cup logic board. If **any** wire fails, replace the harness. If **all** wires pass, replace the cup logic board. If the problem persists, replace the driver motor. (Refer to Figure 5.6.)

**FIGURE 5.7.**

Location of position P2

Make sure the harness at the connection on the logic board is tight, with no wires loose, backed out, etc.

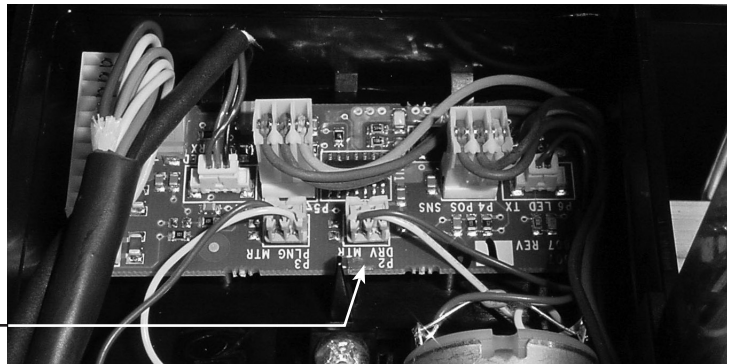

Position P2

**FIGURE 5.8.**

Gears inside cup

Ensure that the gears are seated properly in their correct positions.

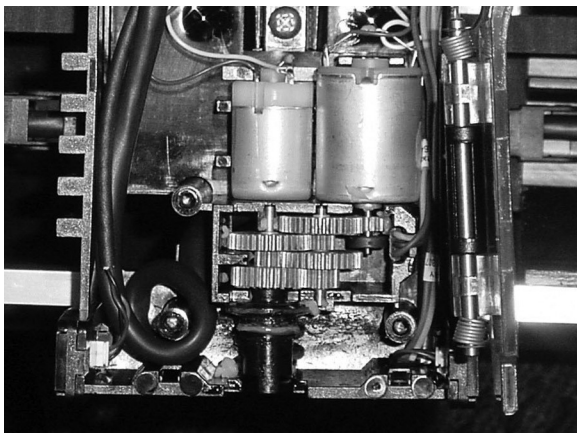
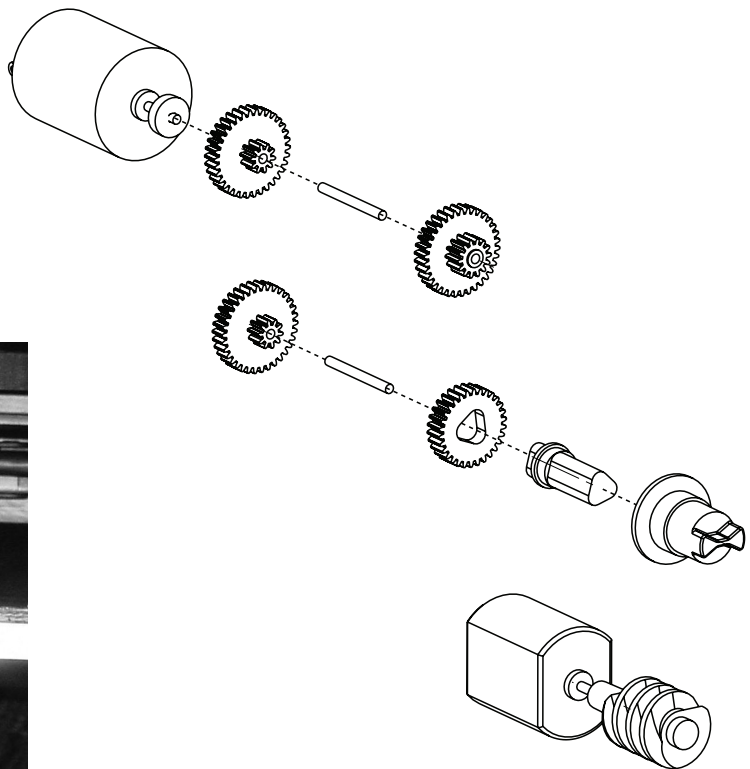

# SECTION 5: Troubleshooting

---

## IV. Sensor Test

Pressing <enter> at `Sensor Test` will cause the vender to display the current state of the sensors on the DMC (Drive Mechanism Controller board). The following will be displayed:

```
MAG (0/1) Y (0/1) CS (0/1)
PDOOR (0/1) BIN (0/1)
```

These codes correspond to the following:

- A. MAG corresponds to the Hall Effect home sensor that is used for finding the home position in the X-axis.
- B. Y corresponds to the Y-axis home sensor.
- C. CS corresponds to the cup sensor.
- D. PDOOR corresponds to the port door.
- E. BIN corresponds to the delivery bin sensors (emitter and detector).
- F. 0 or 1 corresponds to the sensor's state: 0 = off, 1 = on.

This test allows service personnel to observe if there are any problems with any of these sensors. Pressing <exit> will terminate the test. **Note:** *The sensor test can be performed with the door OPEN or CLOSED.*

**NOTE:** If **all** sensor tests fail, check for 5 VDC on the black and green wires at pinout P1 on the cup logic board. If voltage **is** found, replace the cup logic board. If **no** voltage is found, replace the DMC board.

### A. MAG

On the front of the cup (as viewed from inside the vender's door), there are three visible wires (red, green, and black) that run into a sensor. (Refer to Figure 5.9.) This is the Hall Effect sensor, which detects the home position magnet located under the bottom shelf. Place a magnetic screwdriver or other *south-polar* magnetic device directly in front of this sensor. The display should change from "MAG 0" to "MAG 1." **NOTE:** *If no magnetic device is available, place the cup in the middle of the door, then close the door completely. The cup will then perform a homing routine. As the cup passes the homing magnet, the display should briefly change from "MAG 0" to "MAG 1."*

1. Make sure the X-home magnet bracket mounted under the bottom product shelf is in the proper position. The magnet should be facing you and should be flush with the front edge of the bottom shelf. (Refer to Figure 5.29.)
2. If the display does not change, remove the top of the cup, and check the harness connection at pinout P4 on the cup logic board. (Refer to Figure 5.10.) Make sure there are no loose wires and the connection is tight.
3. Using a voltmeter, check for 5 VDC on pins 1 and 2 (black and green wires) at pinout P4 on the cup logic board. If **no** voltage is found, replace the logic board.
4. Using an ohmmeter, check for continuity on all wires in the harnessing from the DMC to the cup logic board. If **any** wire fails, replace the harness. If **all** wires pass, replace the cup logic board. If the problem persists, replace the Hall Effect sensor.

## SECTION 5: Troubleshooting

**FIGURE 5.9.**

Front of product cup

The Hall Effect sensor is located on the front of the cup. Three wires run into the sensor (red, green, and black). Place a magnetic device directly in front of the sensor to test it in Sensor Test.

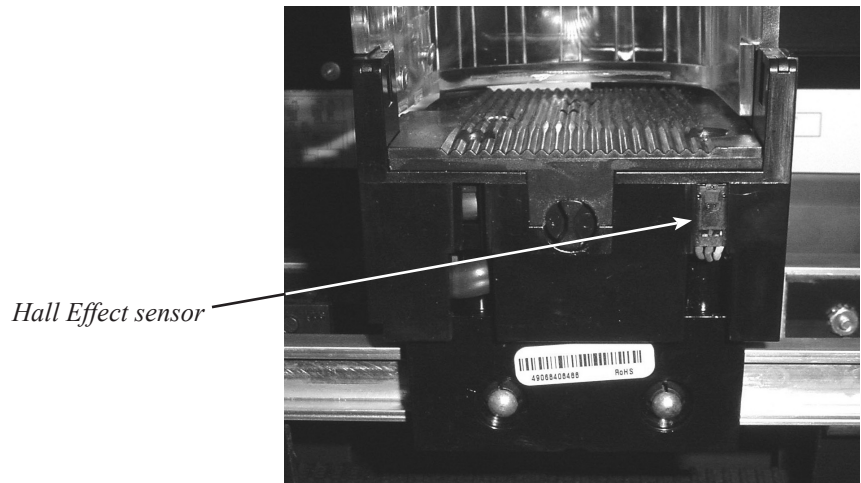

**FIGURE 5.10.**

Location of position P4

Make sure the harness at the connection on the logic board is tight, with no wires loose, backed out, etc.

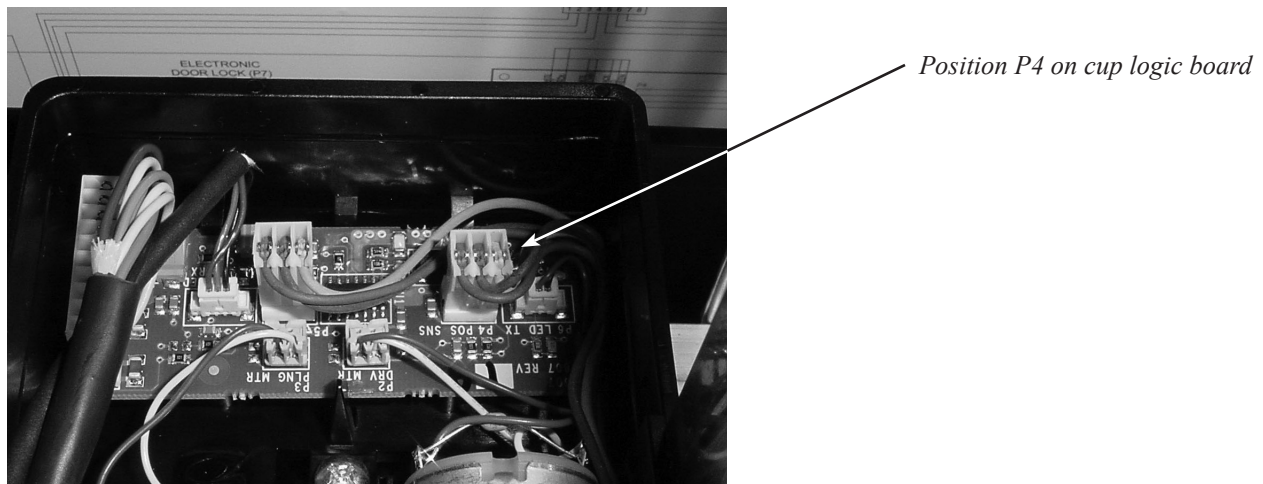

### B. Y

The Y-home switch is located below the elevator arm. This switch is covered by a black plastic cover. To test this switch, begin with the elevator arm all the way down. The display should show “Y 1.” Lift the elevator arm up, and the display should change to “Y 0.”

1. If the display does not change, place the elevator arm all the way down on the Y-home switch and ensure it is parallel with the bottom of the main door. (Refer to Figure 5.11.)
2. Ensure that the black plastic cover over the switch is not holding the switch down. If it is, bend the plastic upward so that it completely disengages the switch.
3. Check the wiring to the Y-home switch.
4. Check for 5 VDC on the black and red wires (pins 6 and 7) at position P1 on the DMC board.
5. If all the above is good, replace the Y-home switch. If this does not fix the issue, replace the DMC board.

## SECTION 5: Troubleshooting

**FIGURE 5.11.**

Elevator arm and vertical home switch

*Make sure the elevator arm is level and it is all the way down on the vertical home switch.*

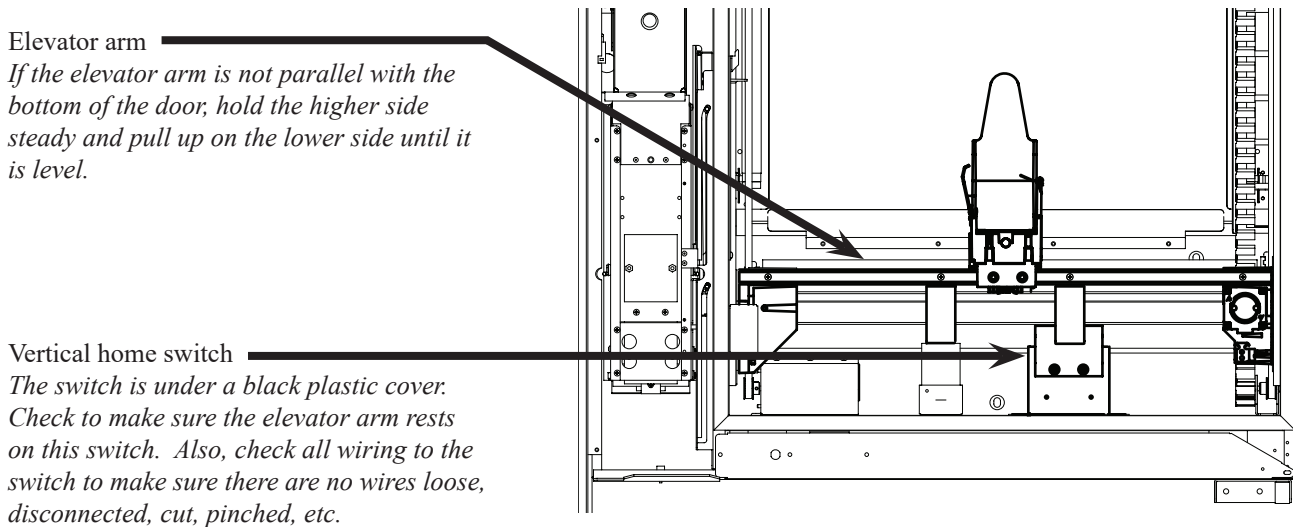

### C. CS

The cup sensor is actually two separate components: an infrared emitter, located on the right side of the cup; and a detector, on the left side of the cup. (Refer to Figure 5.12.) To test the sensors, break the infrared beam by placing a hand or other item in front of one of the sensors. The display should change from “CS 0” to “CS 1.”

1. If the display does not change, check the emitter lens (clear) and detector filter (dark) to make sure they are not creased or wrinkled. (Refer to Figure 5.13.) If the lens and filter are creased or wrinkled, they could possibly slide down below the emitter or detector, causing the optics to fail. If one of the lenses is creased or wrinkled, replace it.
2. Remove the top of the cup, and check the harness connections at pinouts P6 and P7 on the cup logic board. (Refer to Figure 5.14.) Make sure there are no loose wires and the connections are tight. Also, check the connections at the emitter and detector boards.
3. Using an ohmmeter, check for continuity on all wires in the harnessing from the DMC to the cup logic board. If **any** wire fails, replace the harness. If **all** wires pass, replace the cup logic board. If the problem persists, replace the cup emitter and detector.

# SECTION 5: Troubleshooting

**FIGURE 5.12.**  
Locations of cup optic sensors

*Optic sensors (one on each side)*

*Emitter: right side, clear lens  
Detector: left side, dark filter*

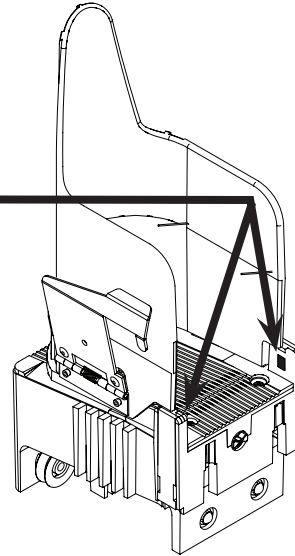

**FIGURE 5.13.**  
Emitter lens and detector filter  
*Make sure the lens and filter are not creased or wrinkled.*

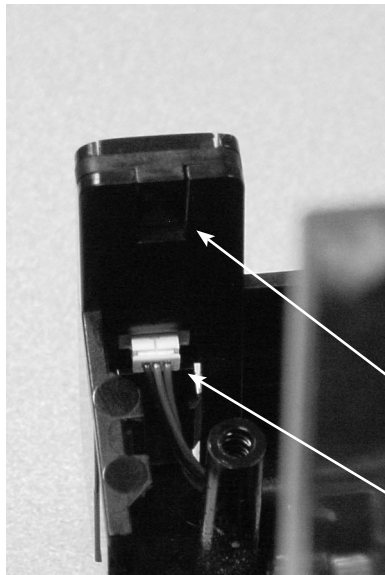

*Location of clear lens*

*Emitter board harness*

*Location of filter (dark lens)*

*Detector board harness*

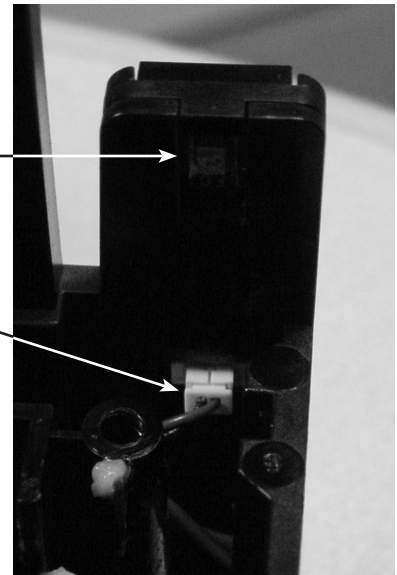

**FIGURE 5.14.**  
Locations of position P6 and P7 on logic board  
*Make sure the harnesses at the connections on the logic board are tight, with no wires loose, backed out, etc.*

*Position P6*

*Position P7*

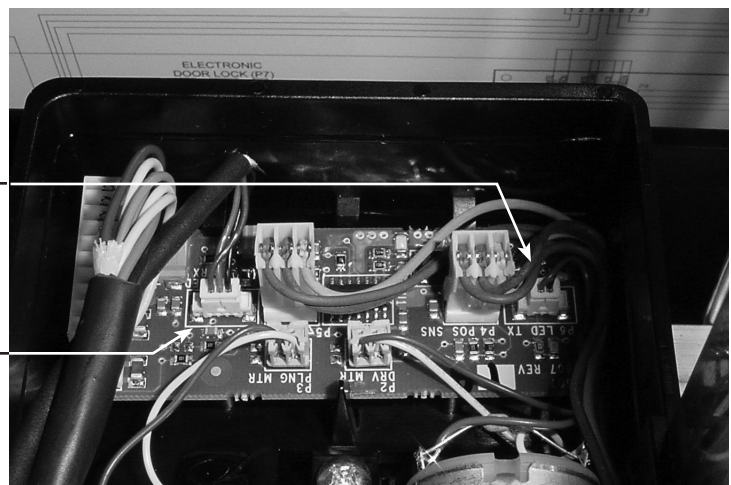

# SECTION 5: Troubleshooting

## D. PDCOR

The port slide switch is located above the port slide door, adjacent to the product bin. To test the switch, push the port slide down. The display should change from “PDCOR 0” to “PDCOR 1.”

1. If the display does not change, check the wiring and mating of the port slide switch and the linkage arm. (Refer to Figure 5.15.)
2. Check for 5 VDC on the red and black wires at the port slide switch. If voltage **is** found, check to make sure the port slide is sliding all the way up and engaging the switch completely. If it is, replace the switch. If voltage is **not** found, skip to Step E.
3. If the switch is **not** being engaged completely, check the port security latch to make sure it is not stuck. If the latch is stuck, it may not move up and down freely. (Refer to Figure 5.16.)
4. If the latch is not stuck in Step C, check the port slide springs to make sure they are not broken or detached from the port slide. (Refer to Figure 5.17.) If they are broken, replace them.
5. If voltage was not found in Step B, check for 5 VDC coming from pin 3 (black wire) at pinout P4 on the DMC board. If **no** voltage is found, replace the DMC board. If voltage **is** found, trace the harnessing from the DMC board to the port slide switch. If any problems are found, repair them or replace the harnessing.

**FIGURE 5.15.**

Port slide switch and linkage arm

Check the wiring to make sure it is not loose or disconnected. Also, make sure the switch and the metal linkage arm are mated properly.

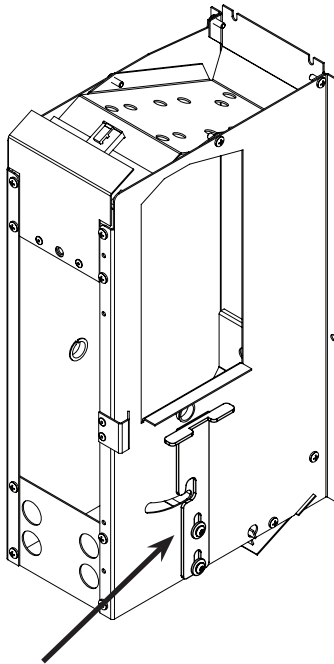
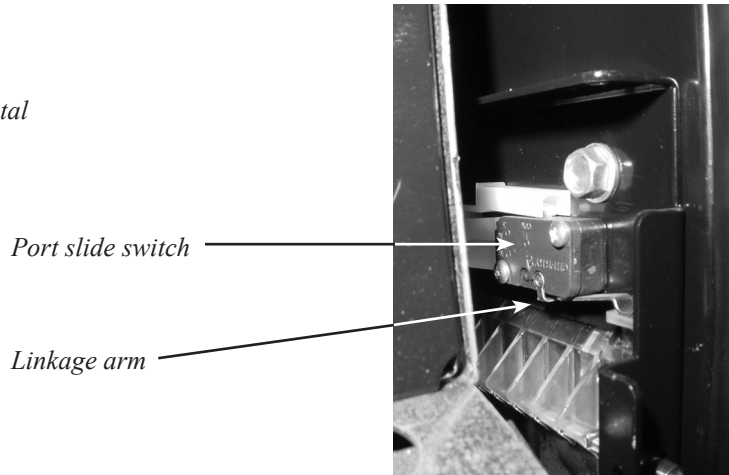

**FIGURE 5.16.**

Port security latch

Make sure this latch is not stuck. It should move up and down freely.

**FIGURE 5.17.**

Port slide springs

The springs should be attached to the port slide assembly at both ends.

Port slide springs (two springs, shaded in black in this illustration)

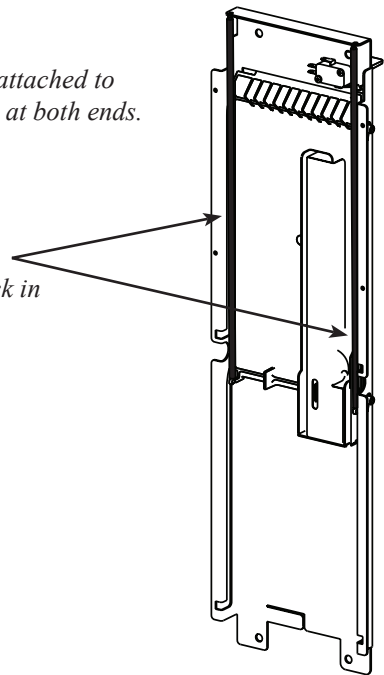



## SECTION 5: Troubleshooting

### E. BIN

Below the product bin, there is an infrared emitter. Above the product bin, below the coin box, there is a detector. The emitter projects 2 or 4 infrared beams, which are received by the detector. If an infrared beam is broken, the display will show "Remove Product" in sales mode (door closed). To test these sensors, open the product bin. In *Sensor Test*, the display should change from "BIN 0" to "BIN 1."

1. If the display does not change, check to make sure the port bin is flush with the door. Also, make sure the port bin is relatively clean inside and clear of any debris that could be blocking the emitter and detector boards' infrared beam. (Refer to Figure 5.18.) If the port bin is hanging open, reset the security latch on the port bin. (Refer to Figure 5.19.) If it doesn't reset, check the white port bushings on each side of the port assembly. (Refer to Figure 5.20.) If the bushings are broken, replace them.

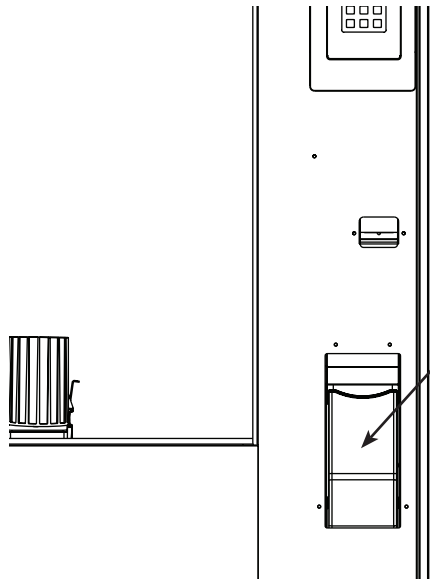

**FIGURE 5.18.**

Port bin

*The front of the port bin should be flush (even) with the front of the door and should be clean inside.*

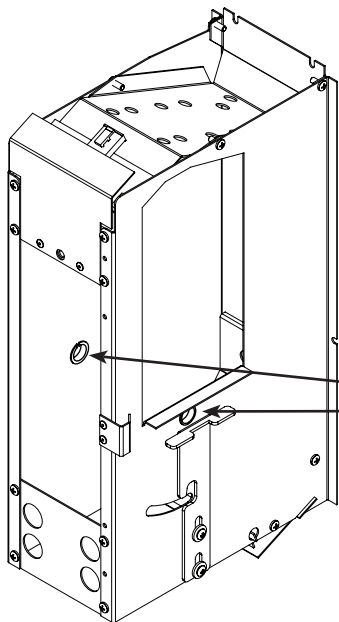

**FIGURE 5.19.**

Port security latch

*Make sure this latch is not stuck. It should move up and down freely.*

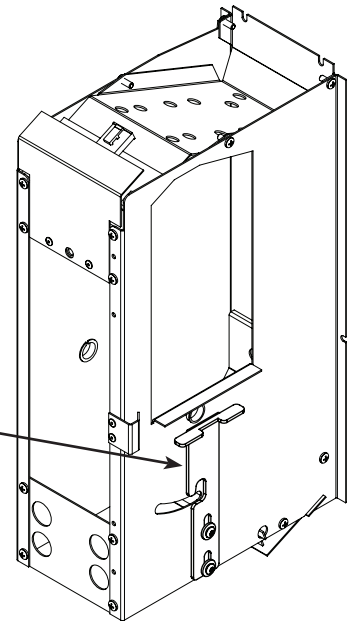

**FIGURE 5.20.**

White port bushings

*Make sure these bushings are not broken. (Note: Port box housing shown with product bin removed for clarity.)*

## SECTION 5: Troubleshooting

2. Check the harnessing to the emitter and detector boards located in the product bin. (Refer to Figure 5.21.)
3. Check the harnessing on both control boards, at position P4 on the DMC board (5 VDC on the black and brown wires) and at position P11 on the VMC board (5 VDC on the red and white wires). If no voltage is found, replace that particular board.
4. Check for coins or debris under or on top of the emitter and detector boards. Remove and reseat the emitter and detector boards, ensuring that the metal plate the emitter board sits on is properly inserted into the two metal tabs under the port assembly. (Refer to Figure 5.22.)
5. If all the above is good, replace the detector board first. Test the vend mechanism. If the error still exists, replace the emitter board.

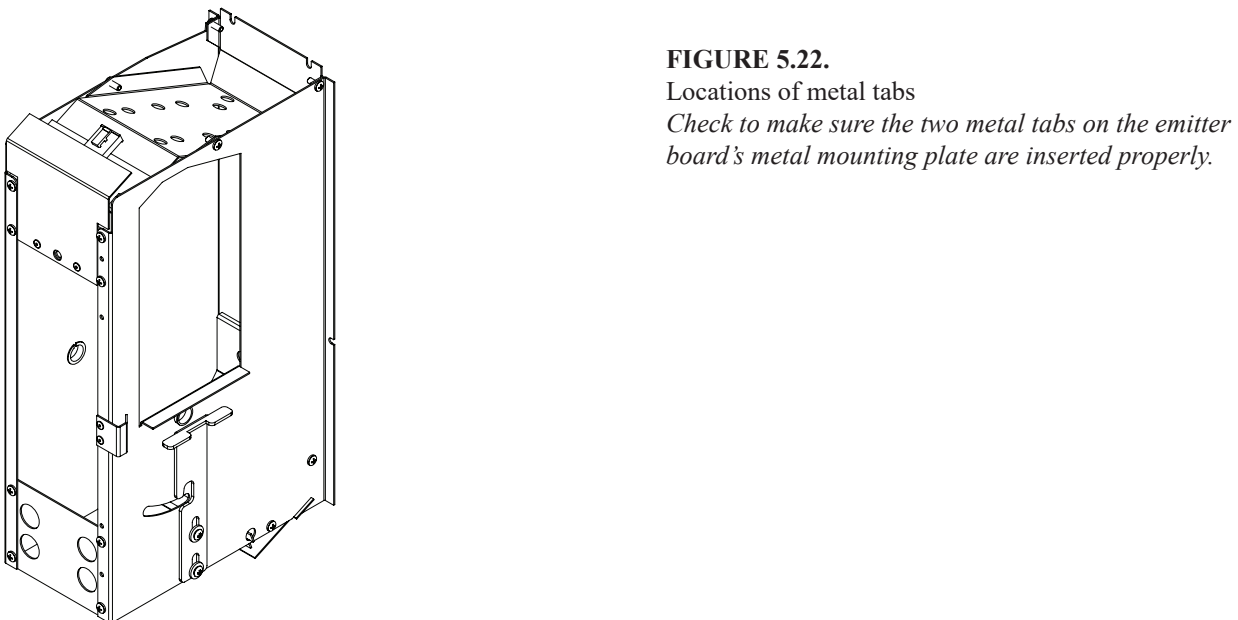
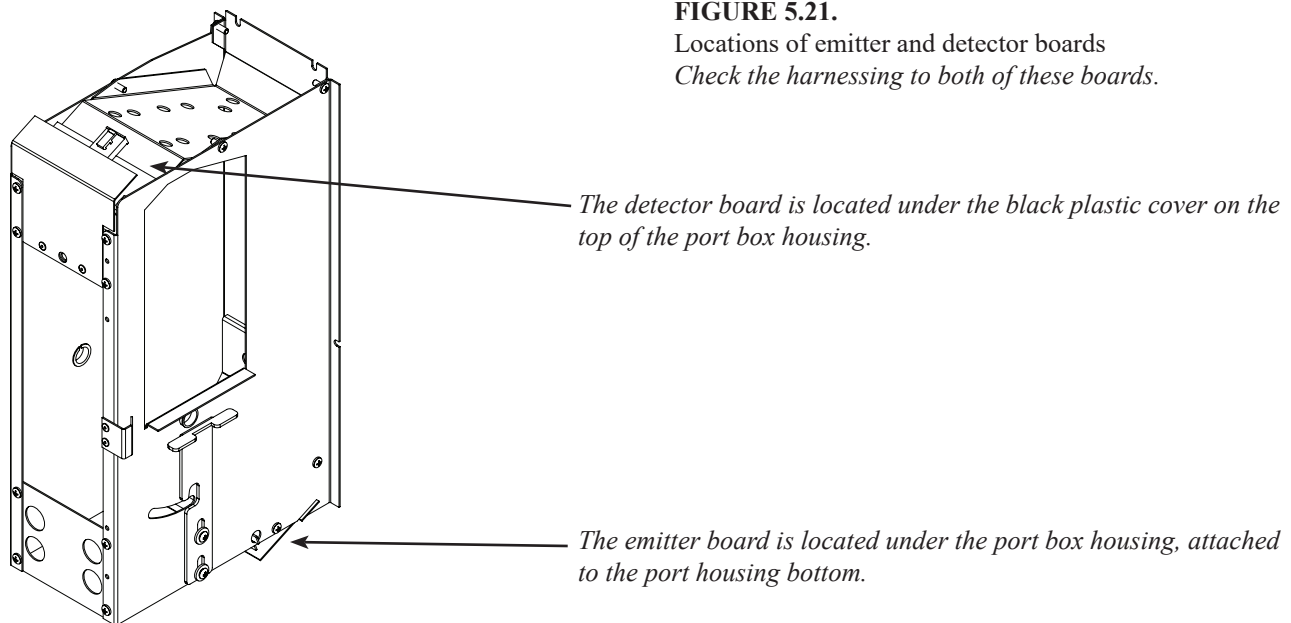

# SECTION 5: Troubleshooting

## V. Motor / Encoder Test

After pressing <enter> at **Motor / Encoder Test**, the display will show in real time the encoder counts of the cup's position. Pressing <up> or <down> will move the cup +450 or -450 encoder ticks, respectively. Pressing <right> or <left> will move the cup +300 or -300 encoder ticks, respectively. This test allows service personnel to determine whether or not the encoders are counting correctly and whether or not the belts are faulty. Pressing <exit> will terminate the test. **Note:** *The motor / encoder test can be performed with the door OPEN or CLOSED.*

### **Possible problems:**

- A. Y-encoder count is off by +/-3 ticks or more
- B. X-encoder count is off by +/-3 ticks or more
- C. Encoder count is correct, but the belts do not move the mechanism the correct distance

### **A. Y-encoder count is off by +/-3 ticks or more.**

1. If after moving the cup up or down, the count is less than 447 ticks or more than 453 ticks from the previous value, check the harnessing to the Y-encoder. Make sure the connection at the encoder is tight, with no wires loose, backed out, etc. (Refer to Figure 5.23.)
2. Ensure that the harnessing at pinout P1 on the DMC board is tight, with no wires loose, backed out, etc.
3. Using an ohmmeter, check for continuity on all wires in the harnessing from the DMC to the Y-encoder. If any wire fails, replace the harness. If all wires pass, replace the Y-encoder. If the problem persists, replace the DMC.

**FIGURE 5.23.**

Y-motor connection

*Make sure the harnesses at the connections on the Y-motor are tight, with no wires loose, cut, pinched, backed out, etc.*

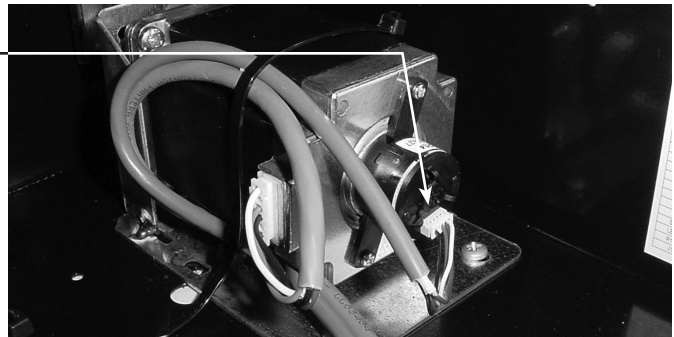

### **B. X-encoder count is off by +/-3 ticks or more.**

1. If after moving the cup right or left, the count is less than 297 ticks or more than 303 ticks from the previous value, carefully remove the X-motor encoder cap and check for condensation. (Refer to Figure 5.24.) If condensation is found, allow the encoder to dry, and search for the cause of the condensation.
2. Check the harnessing to the X-encoder. Make sure the connection at the encoder is tight, with no wires loose, backed out, etc. (Refer to Figure 5.25.)
3. Ensure that the harnessing at pinout P2 on the DMC board is tight, with no wires loose, backed out, etc.
4. Using an ohmmeter, check for continuity on all wires in the harnessing from the DMC to the X-encoder. If any wire fails, replace the harness. If all wires pass, replace the X-encoder. If the problem persists, replace the DMC.

**FIGURE 5.24.**

X-motor encoder cap

*Remove this cap and check for condensation (moisture) under it.*

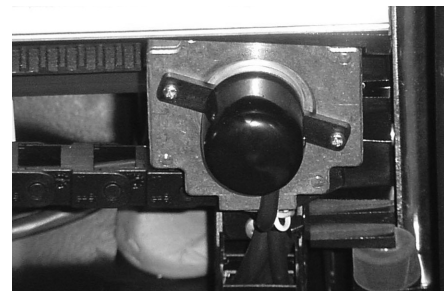

## SECTION 5: Troubleshooting

**FIGURE 5.25.**

X-motor connections  
Make sure the harnesses at the connections on the X-motor are tight, with no wires loose, cut, pinched, backed out, etc.

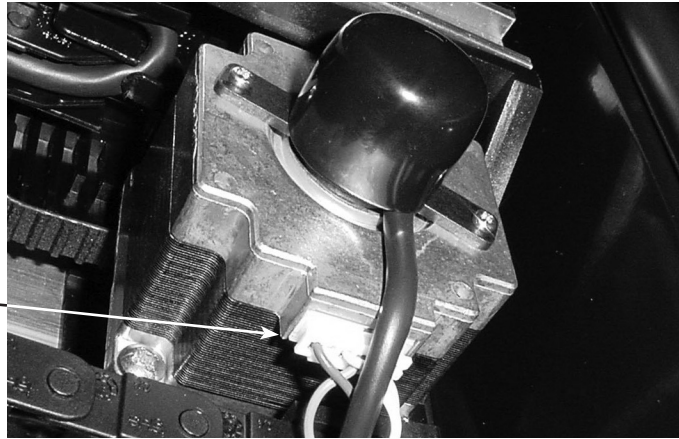

### C. Encoder count is correct, but the belts do not move the mechanism the correct distance.

1. Y-axis (up and down movement)
  - a. Check the tension of the Y-belts. If the belts are loose, adjust the belt tension. To tighten the belts, first loosen the security screw, then adjust the tension screw. Once the belt has proper tension, re-tighten the security screw. (Refer to Figure 5.26.)
  - b. Check the top idler assembly and Y-motor for loose pulleys. (Refer to Figure 5.27.) If loose pulleys are found, replace them. If the pulley on the motor is loose, replace the motor.
  - c. If tension is correct and no pulleys are found to be loose, replace the Y-belts.

**FIGURE 5.26.**

Y-belt tension adjusters  
To tighten the tension of the belts, turn the tension screw clockwise.

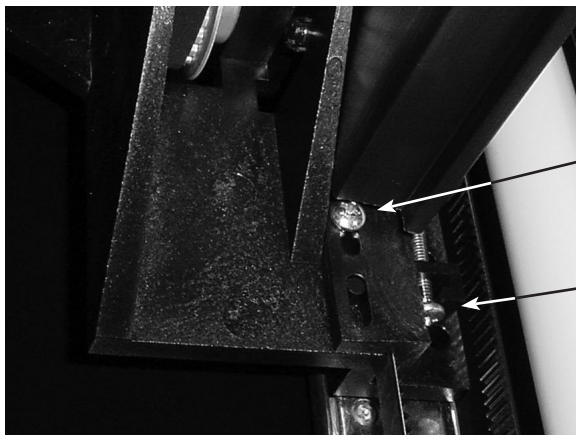

Security screw, left side

Y-belt tension screw, left side

The security screw for the right side is located behind this plastic piece.

Y-belt tension screw, right side

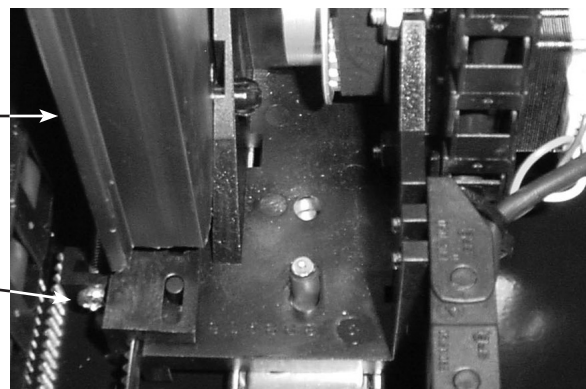

## SECTION 5: Troubleshooting

**FIGURE 5.27.**

### Y-axis pulleys

Check the top pulleys and the pulley on the Y-motor to make sure they are not loose or slipping. Also, check the screws which secure the top idler assemblies to make sure they are not loose.

*Y-motor pulley*

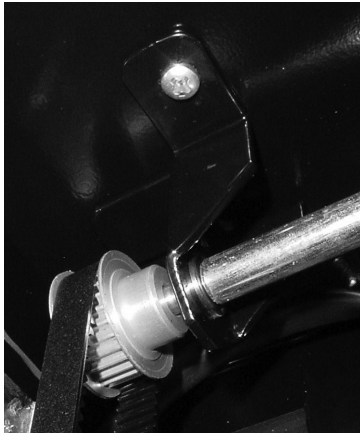
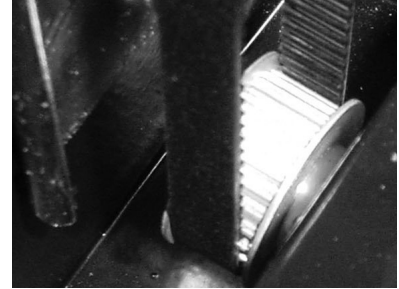

*Top left idler screw and pulley*



*Top right idler screw and pulley*

2. X-axis (left and right movement)
  - a. Check the X-belt for proper tension. When the X-belt has proper tension, it should be firm but not tight.
  - b. Check the X-motor pulley for slippage. (Refer to Figure 5.28.) If the pulley on the motor is loose, replace the motor. Also, check the X-belt idler pulley for slippage. No belt slippage on the pulleys should be heard while the X-belt is running.
  - c. If tension is correct and neither pulley is found to be loose, replace the X-belt.

**FIGURE 5.28.**

### X-axis motor pulley

Check the pulley on the X-motor to make sure it is not loose or slipping, and check the X-axis belt for proper tension. No slippage should be heard when the X-belt is properly adjusted.

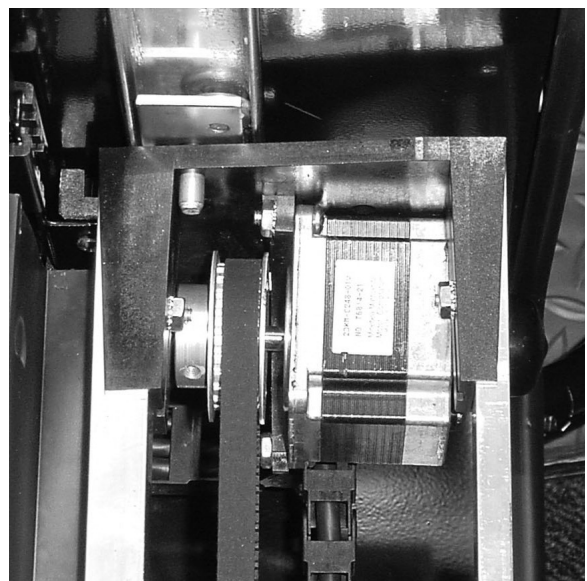

# SECTION 5: Troubleshooting

## VI. Production Test

After pressing <enter> at `Production Test`, the vender will execute the production test. “`Testing`” will be displayed while the test is carried out. If the vender passes the test, “`Pass`” will be displayed. Upon any failure in the test, the test will be terminated and a failure reason will be displayed. This test only displays the last failure that caused the test to be terminated. A list of potential failures is show below. *Note: The production test can only be performed with the door CLOSED.*

- A. “`Failure X#`” indicates a failure in the X-axis.
- B. “`Failure Y#`” indicates a failure in the Y-axis.
- C. “`Magnet RC`” indicates a failure to find the magnet corresponding to the position for row “`R`” and column “`C`.” (Example: “`Magnet 25`” indicates an inability to find the magnet for cell 25.)
- D. “`EOT RC`” indicates a failure to get to the end of travel of row “`R`” and cell “`C`.”
- E. “`SPEED`” indicates a failure to adjust motor speed.
- F. “`SIDE S`” indicates a failure in the perimeter test to move along side “`S`.”

## VII. Multiple Home Test

Pressing <enter> at `Multiple Home Test` will cause the vender to home multiple times. “`Testing`” will be displayed during the test. “`Pass`” will be displayed if the vender passes the test. “`Fail ##`” will be displayed if the vender fails the test, where “`##`” indicates a failure reason. This test allows service personnel to observe if there is any inconsistency in finding the home position. Pressing <exit> will terminate the test and return the display to “`Multiple Home Test`.” *Note: The multiple home test can only be performed with the door CLOSED.*

### Possible problems:

Cup does not find home position

### Cup does not find home position.

- A. Make sure the X-home magnet bracket mounted under the bottom product shelf is in the proper position. The magnet should be facing you and should be flush with the front edge of the bottom shelf. (Refer to Figure 5.29.)

**FIGURE 5.29.**

X-home magnet  
Check to make sure the magnet bracket is flush (even) with the front edge of the bottom shelf.

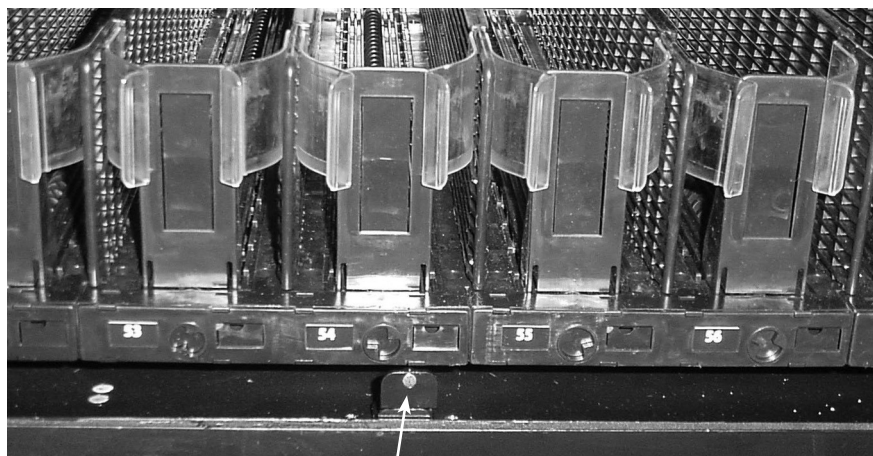

X-home magnet bracket

## SECTION 5: Troubleshooting

- B. Ensure that the elevator arm is parallel with the bottom of the main door. (Refer to Figure 5.30.)
- C. Remove the product cup floor, and check the wiring from the Hall Effect sensor to position P4 on the cup logic board. (Refer to Figure 5.31.)
- D. Using a voltmeter, check for 5 VDC on pins 1 and 2 (black and green wires) at pinout P4 on the cup logic board. (Refer to Figure 5.31.) If **no** voltage is found, replace the logic board.
- E. Using an ohmmeter, check for continuity on all wires in the harnessing from pinout P3 on the DMC board to the cup logic board. If **any** wire fails, replace the harness. If **all** wires pass, replace the cup logic board. If the problem persists, replace the Hall Effect sensor.

**FIGURE 5.30.**

Elevator arm

If the elevator arm is not parallel with the bottom of the door, hold the higher side steady and pull up on the lower side until it is level.

Elevator arm (darker lines)

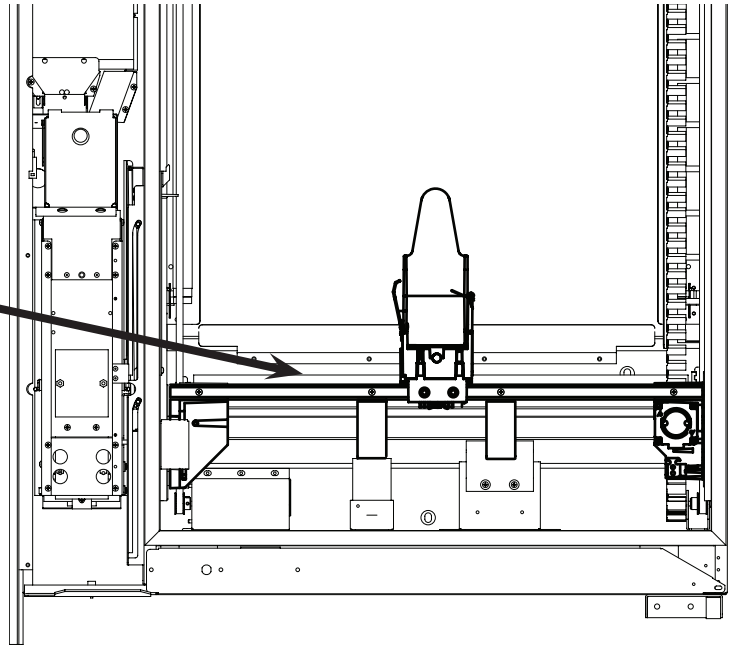

**FIGURE 5.31.**

Locations of position P4 and the Hall Effect sensor

Position P4 on cup logic board

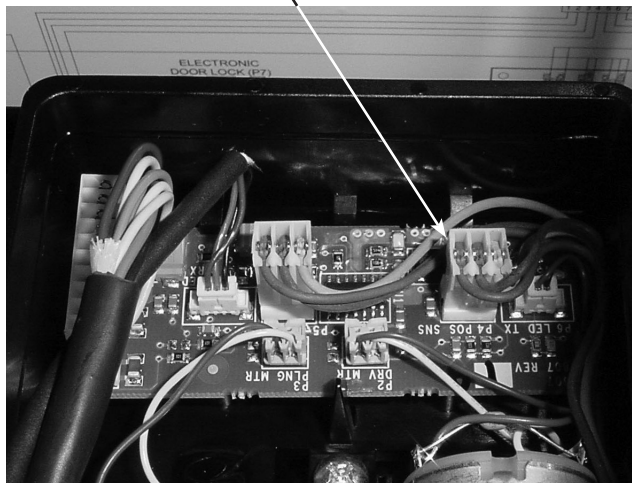

Hall Effect sensor

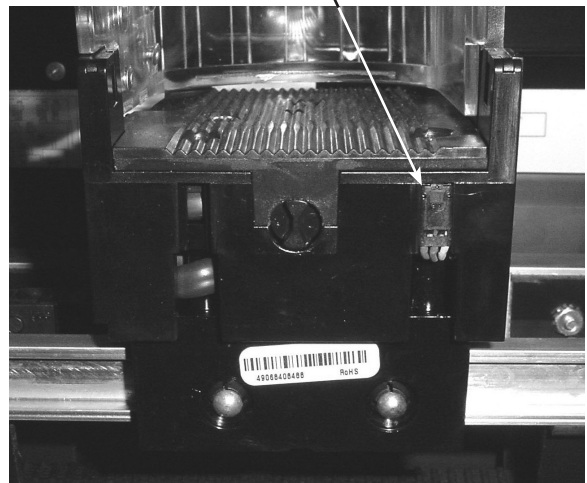

# SECTION 6: Parts Catalog

## RVV Gen II Main Controllers

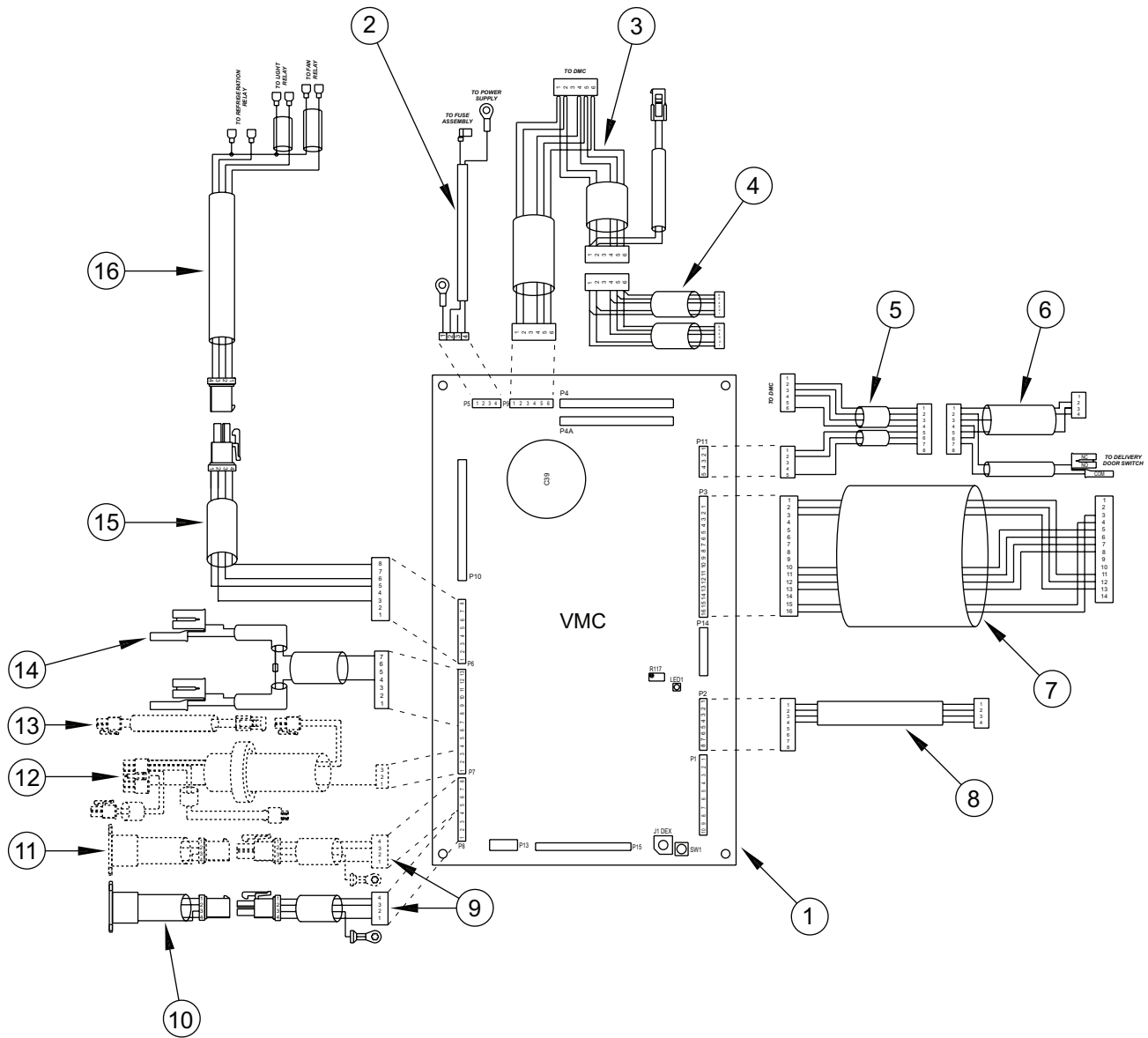

ITEM NO.	DESCRIPTION	PART NUMBER
1	Vender Main Controller (VMC).....	836324
2	Power Supply Harness RVV NG.....	842551
3	VMC / DMC MDB Harness RVV NG.....	842555
4	MDB Split Harness.....	842116
5	Delivery Door Power / Signal Harness RVV NG.....	842552
6	Port / Delivery Door Switch Harness RVV NG.....	842553
7	Touch Pad Harness RVV NG.....	842651
8	Serial Display Harness RVV NG.....	842547
9	Temp. Sensor / Health Sensor Harness, Door Side RVV NG.....	842557
10	Temperature Sensor RVV NG.....	842558
11	Health Sensor RVV NG (Optional).....	842564
12	Electronic Door Lock Harness, Door Side RVV NG (Optional).....	842554
13	Electronic Door Lock Harness, Cabinet Side RVV NG (Optional).....	842465



# SECTION 6: Parts Catalog

## RVV Gen II Main Controllers

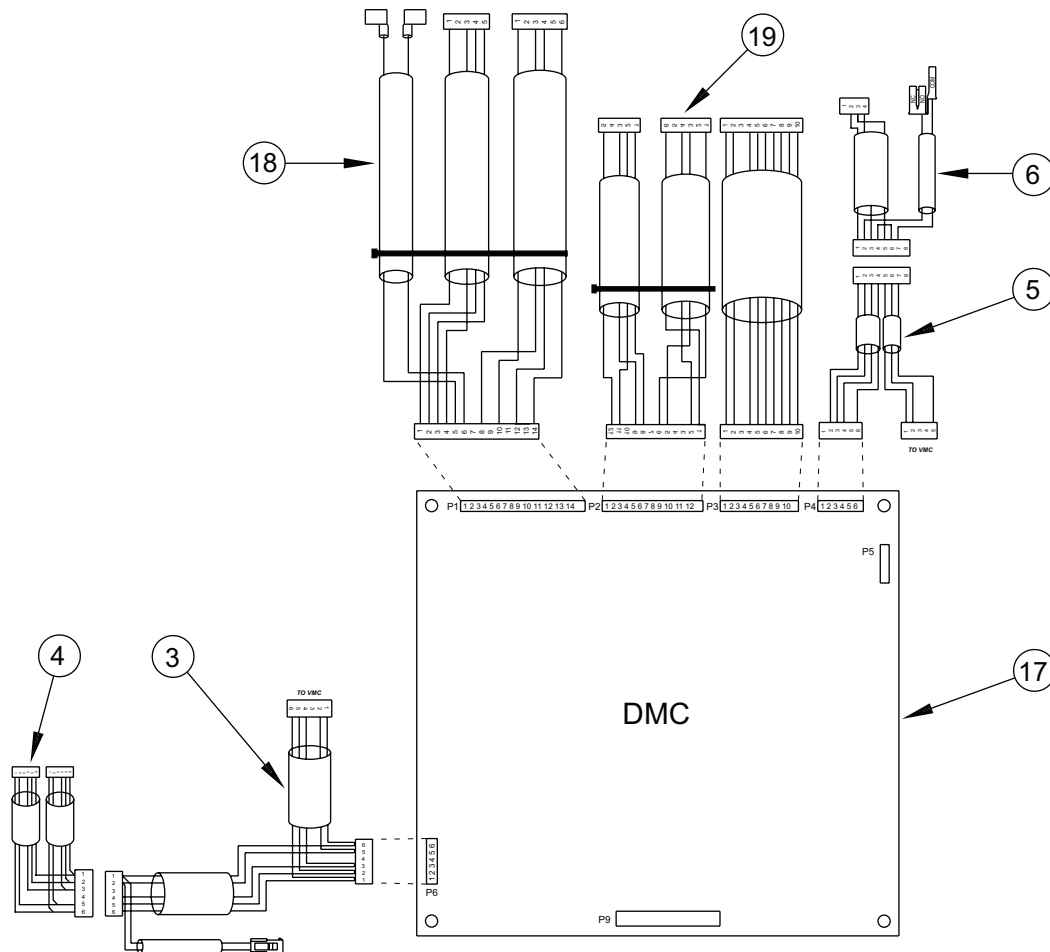

ITEM NO.	DESCRIPTION	PART NUMBER
14	Dual Door Switch Harness RVV NG .....	842694
15	Refrigeration Harness, Door Side RVV NG .....	842559
16	Refrigeration Harness, Cabinet Side RVV NG.....	842530
17	Delivery Main Controller (DMC), EZ Load Shelves (white).....	836319
	- Non-EZ Load Shelves (black).....	836228
18	Y-axis Harness Assembly RVV NG.....	842560
19	X-axis Harness Assembly RVV NG, DMC to Cup, Board Side.....	842630
	- DMC to Motor / Encoder, Board Side .....	842631
	- Large Cable Chain to Cup and Motor / Encoder.....	842632

# SECTION 6: Parts Catalog

## RVV Gen II Door Assembly, TriTeq Lock, Rear

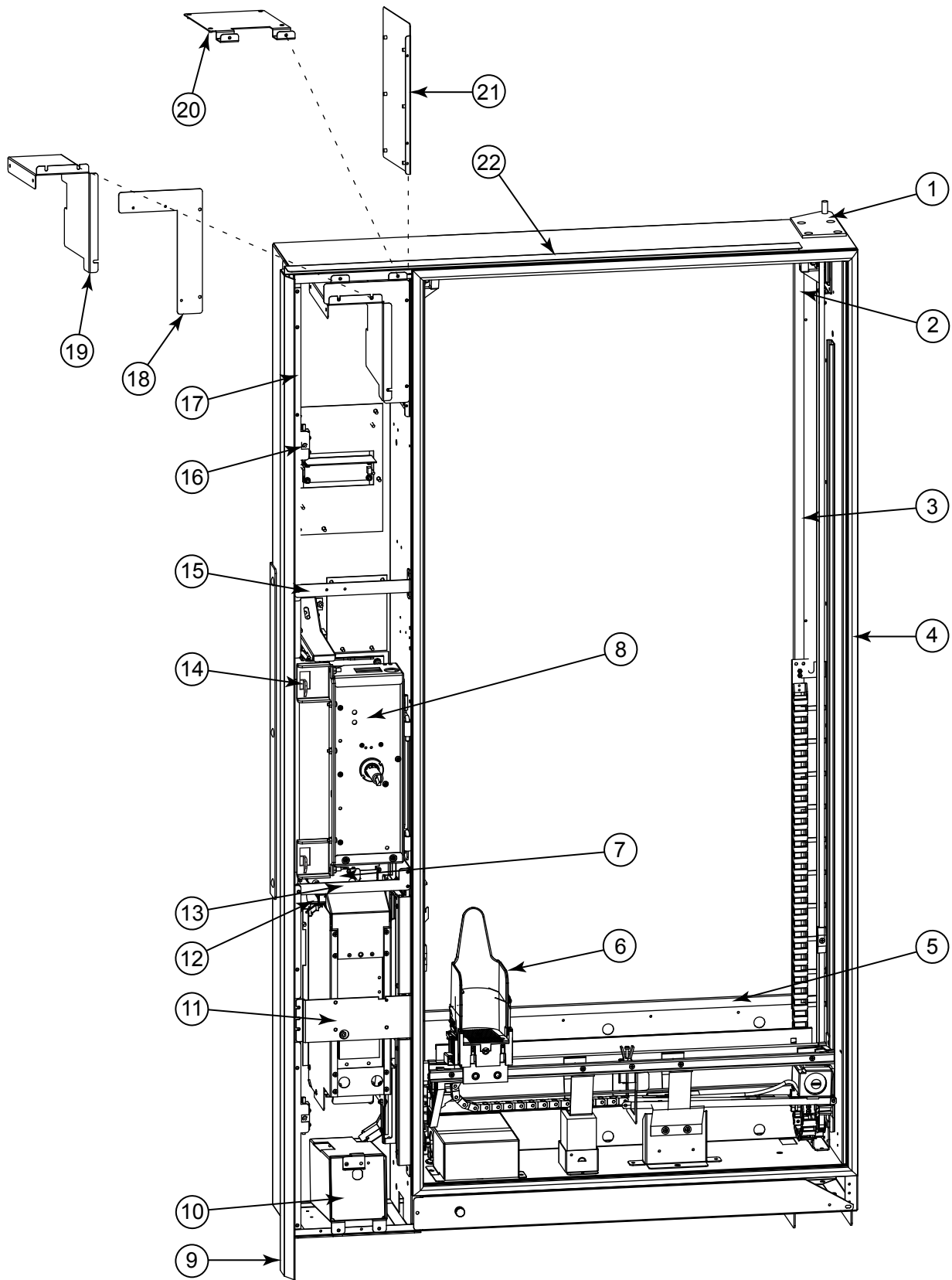

# SECTION 6: Parts Catalog

## RVV Gen II Door Assembly, TriTeq Lock, Rear

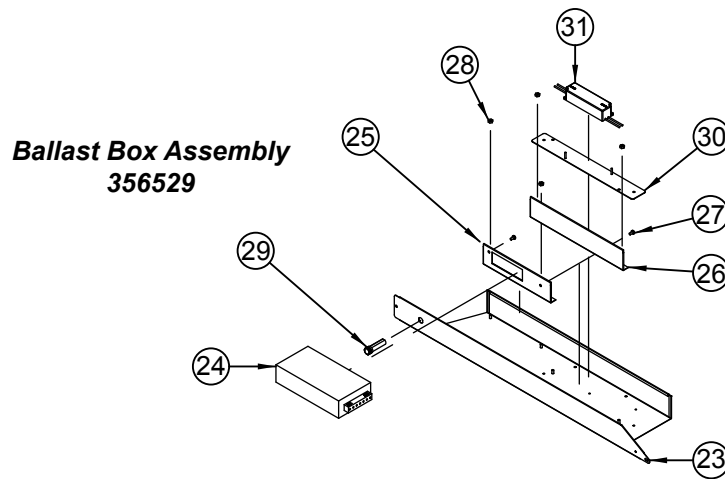

ITEM NO.	DESCRIPTION	PART NO.	ITEM NO.	DESCRIPTION	PART NO.
1	Top Door Hinge Assembly.....	810120	16	Door Switch.....	835023
2	Lampholder .....	842565	17	Harness Retainer .....	394557
3	Glass Retainer, Left .....	356947	18	Control Board Cover .....	356944
	- Right .....	356946	19	Validator Cover.....	356945
4	Main Door Gasket.....	815770	20	Control Board Plate, Small.....	356591
5	Glass Retainer, Top / Bottom .....	350533	21	Control Board Plate, Large .....	356589
6	Cup, with Harness.....	394701	22	Rain Guard.....	394513
7	Changer Bracket Assembly.....	394587	23	Ballast Box .....	356515
8	TriTeq Lock Assembly .....	394920	24	Power Supply .....	838039
9	Vandal Panel, Door .....	394902	25	Power Supply Mounting Angle ....	356519
10	Coin Box, with Latch .....	366590	26	Ballast Shield .....	356531
	- Coin Box Housing .....	393517	27	Screw, M4-0.7 x 8 mm .....	E901106
11	Port Spacer Stiffener.....	394515	28	Keps Nut, #8-32 .....	E905001
12	Coin Cup, TriTeq .....	394599	29	Fuseholder .....	842531
13	Lower Door Brace, TriTeq .....	394903	30	Mounting Plate, LED Power Supply .....	356652
14	TriTeq Latch .....	394900	31	LED Power Supply.....	838046
15	Upper Door Bracket .....	394524			

# SECTION 6: Parts Catalog

## RVV Gen II Door Assembly, T-handle Lock, Rear

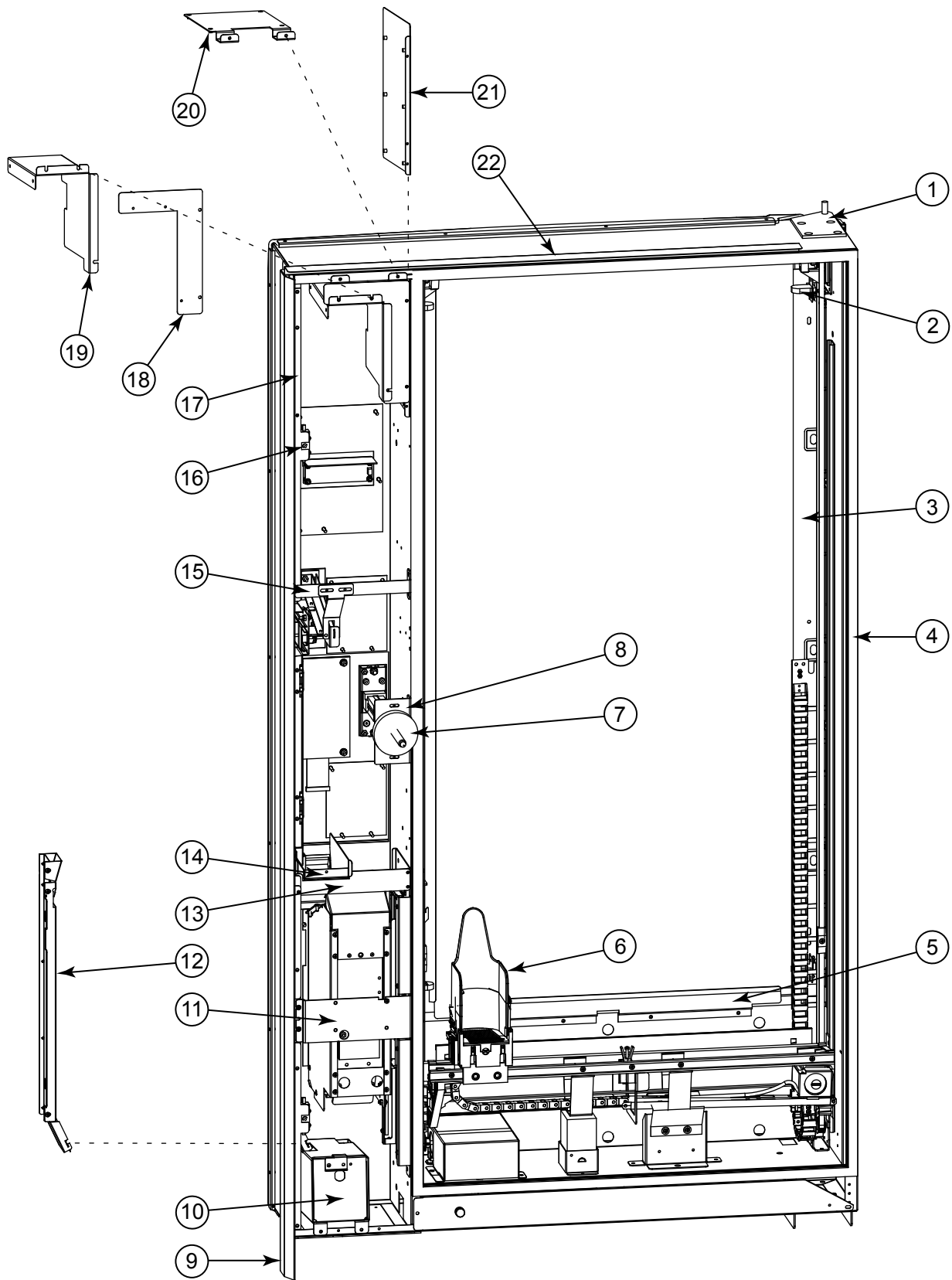

# SECTION 6: Parts Catalog

## RVV Gen II Door Assembly, T-handle Lock, Rear

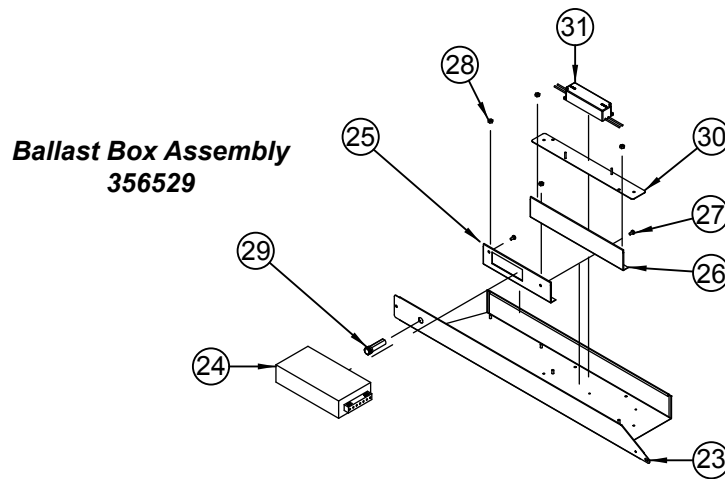

ITEM NO.	DESCRIPTION	PART NO.	ITEM NO.	DESCRIPTION	PART NO.
1	Top Door Hinge Assembly.....	810120	16	Door Switch.....	835023
2	Lampholder .....	842565	17	Harness Retainer .....	394557
3	Glass Retainer, Left .....	356947	18	Control Board Cover .....	356944
	- Right .....	356946	19	Validator Cover.....	356945
4	Main Door Gasket.....	815770	20	Control Board Plate, Small.....	356591
5	Glass Retainer, Top / Bottom .....	350533	21	Control Board Plate, Large .....	356589
6	Cup, with Harness.....	394701	22	Rain Guard.....	394513
7	T-stud Gasket.....	829049	23	Ballast Box .....	356515
8	Stud Bracket .....	393585	24	Power Supply .....	838039
9	Vandal Panel, Door .....	394556	25	Power Supply Mounting Angle ....	356519
10	Coin Box, with Latch .....	366590	26	Ballast Shield .....	356531
	- Coin Box Housing .....	393517	27	Screw, M4-0.7 x 8 mm .....	E901106
11	Port Spacer Stiffener.....	394515	28	Keps Nut, #8-32 .....	E905001
12	Cash Box Chute Assembly .....	394560	29	Fuseholder .....	842531
13	Lower Door Brace, T-handle .....	394544	30	Mounting Plate, LED Power	
14	Enclosed Coin Cup W/A, Rear....	394529		Supply .....	356652
15	Upper Door Bracket .....	394524	31	LED Power Supply.....	838046

# SECTION 6: Parts Catalog

## Elevator / Cup Assembly 394700

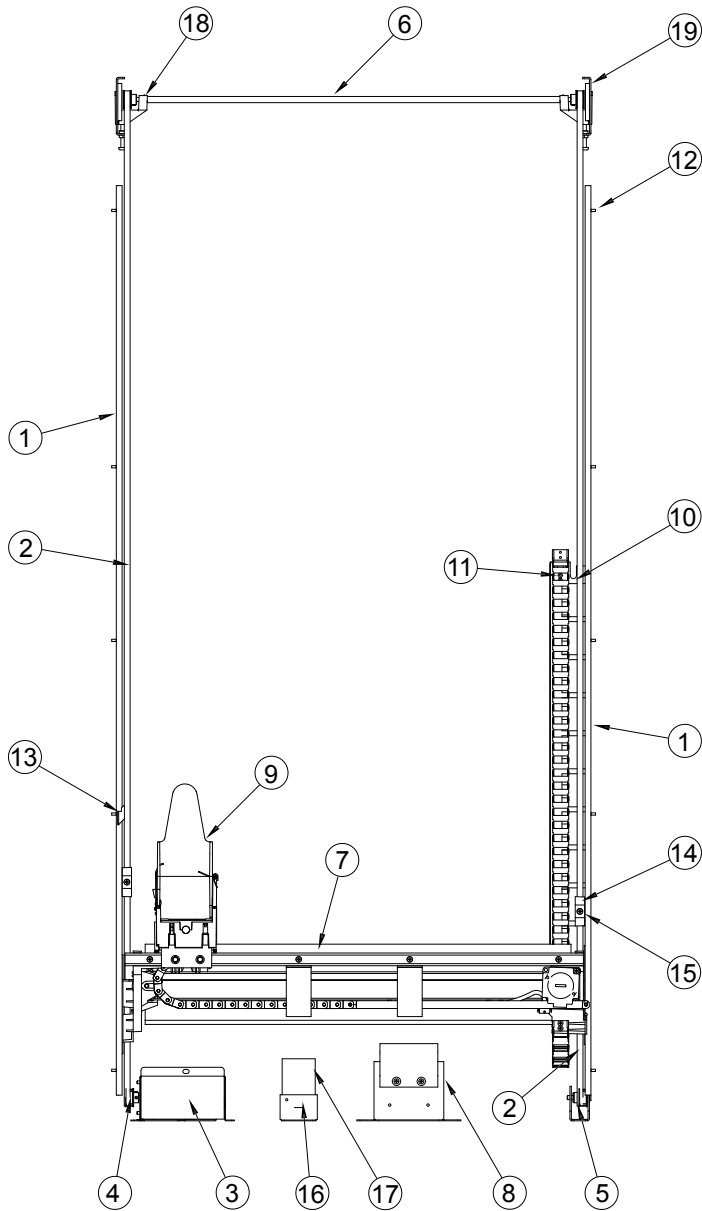

## SECTION 6: Parts Catalog

---

### Elevator / Cup Assembly 394700

ITEM NO.	DESCRIPTION	PART NUMBER
1	Slide, Vertical Rails RVV NG 55" .....	810312
2	Timing Belt RVV NG Quick Remove .....	816161
3	Y-motor Cover RVV NG Quick Remove .....	356639
	- Split Harness Cover .....	356641
4	Y-motor and Pulley Assembly RVV NG Quick Remove .....	356859
5	Bottom Idler Assembly RVV NG .....	356821
6	Top Idler Assembly RVV NG Quick Remove <i>(includes items 18 and 19)</i> .....	356841
7	Elevator Assembly .....	394702
8	Y-home Switch Assembly RVV NG .....	356831
9	Cup Assembly .....	394701
10	Bracket, Cable Chain Guard with Studs RVV NG .....	356823
11	Keps Nut, #4-40 .....	905041
12	Screw, #8-32 x 3/8" Flat Head .....	E901107
13	Trip Bracket RVV NG .....	356819
14	Belt Clamp .....	815661
15	Screw, #8-32 x 5/8" Flat Head .....	901101
	- Keps Nut, #8-32 .....	E905001
16	Foam Pad Bracket .....	356833
17	Foam Pad .....	826054
18	Tensioner, Y-belt RVV NG Quick Remove .....	815684
19	Top Idler Slide Bracket Subassembly .....	363835
•	Split Harness Connector Mount .....	356854

# SECTION 6: Parts Catalog

## Product Cup Assembly 394701

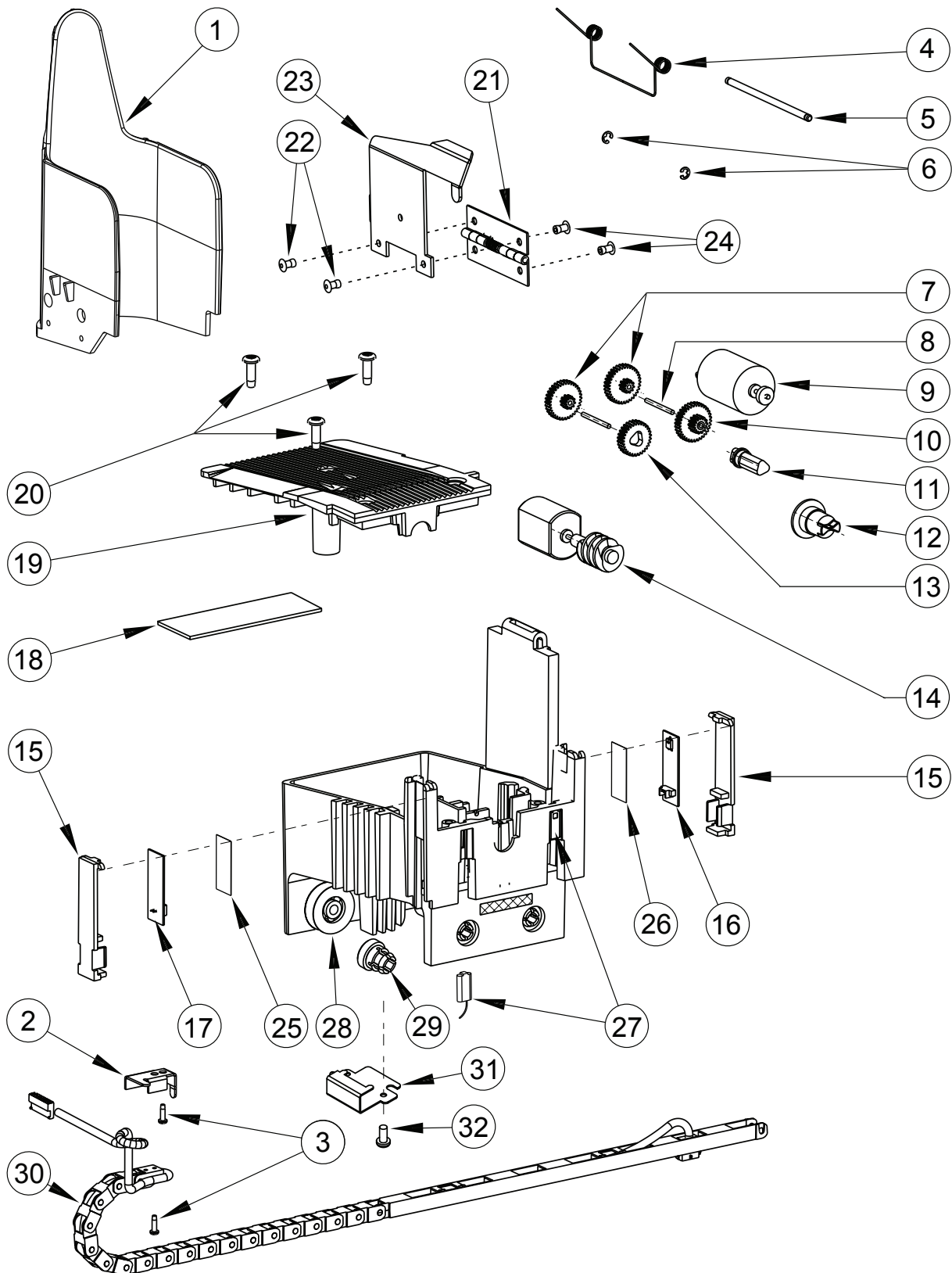



# SECTION 6: Parts Catalog

## Product Cup Assembly 394701

ITEM NO.	DESCRIPTION	PART NUMBER
1	Cup Wall RVV NG.....	815606
	- Cup Wall Assembly RVV NG (includes items 1, 4, 5, 6, 21, 22, and 23).....	356880
2	Cup Harness Retainer RVV NG.....	356815
3	Screw, #8-32 x 3/8" Flat Head .....	E901107
4	Return Spring RVV NG.....	914047
5	Pivot Cup Pin RVV NG .....	803104
6	E-ring Clip .....	906077
7	Gear #1 (48DP, 34T-20T).....	803106
8	Gear Shaft RVV NG.....	803105
9	Drive Motor Assembly RVV NG .....	839051
10	Gear #2 (48DP, 34T-14T).....	803107
11	Drive Shaft RVV NG .....	815610
12	Driver RVV NG.....	815611
13	Gear #3 (48DP, 30T).....	803108
14	Plunger Motor Assembly RVV NG .....	839052
15	Sensor Cover RVV NG .....	815607
16	Cup Emitter Board RVV NG.....	836189
	- Cup Sensor Transmitter Harness (to Cup Emitter Board) .....	842546
17	Cup Detector Board RVV NG .....	836190
	- Optical Receiver Board Harness (to Cup Detector Board) .....	842545
18	Cup Logic Board RVV NG .....	836198
19	Cup Floor RVV NG .....	815605
20	Screw, #8-11 x 1/2" Plastite .....	902036
21	Hinge, Stainless Steel.....	812395
22	Pop Rivet, 1/8" D x 0.39" L.....	E908001
23	Cup Trip Arm RVV NG .....	356816
24	Pop Rivet, 1/8" D x 0.265" L.....	E908009
25	Filter (for Detector).....	815609
26	Clear Lens (for Emitter).....	815608
27	Cup Hall Effect Sensor and Harness .....	842544
28	Pulley, Vee Grooved RVV NG.....	815577
29	Pulley, Guide RVV NG .....	815578
	- Screw-drive, Type U, #7 x 1/2" (secures Pulley, Guide) .....	902038
30	Harness, Elevator Cup Assembly .....	842635
31	Cup Extender .....	356938
32	Screw, #12-1/4" x 1/2".....	902039

# SECTION 6: Parts Catalog

## Elevator Assembly 394702

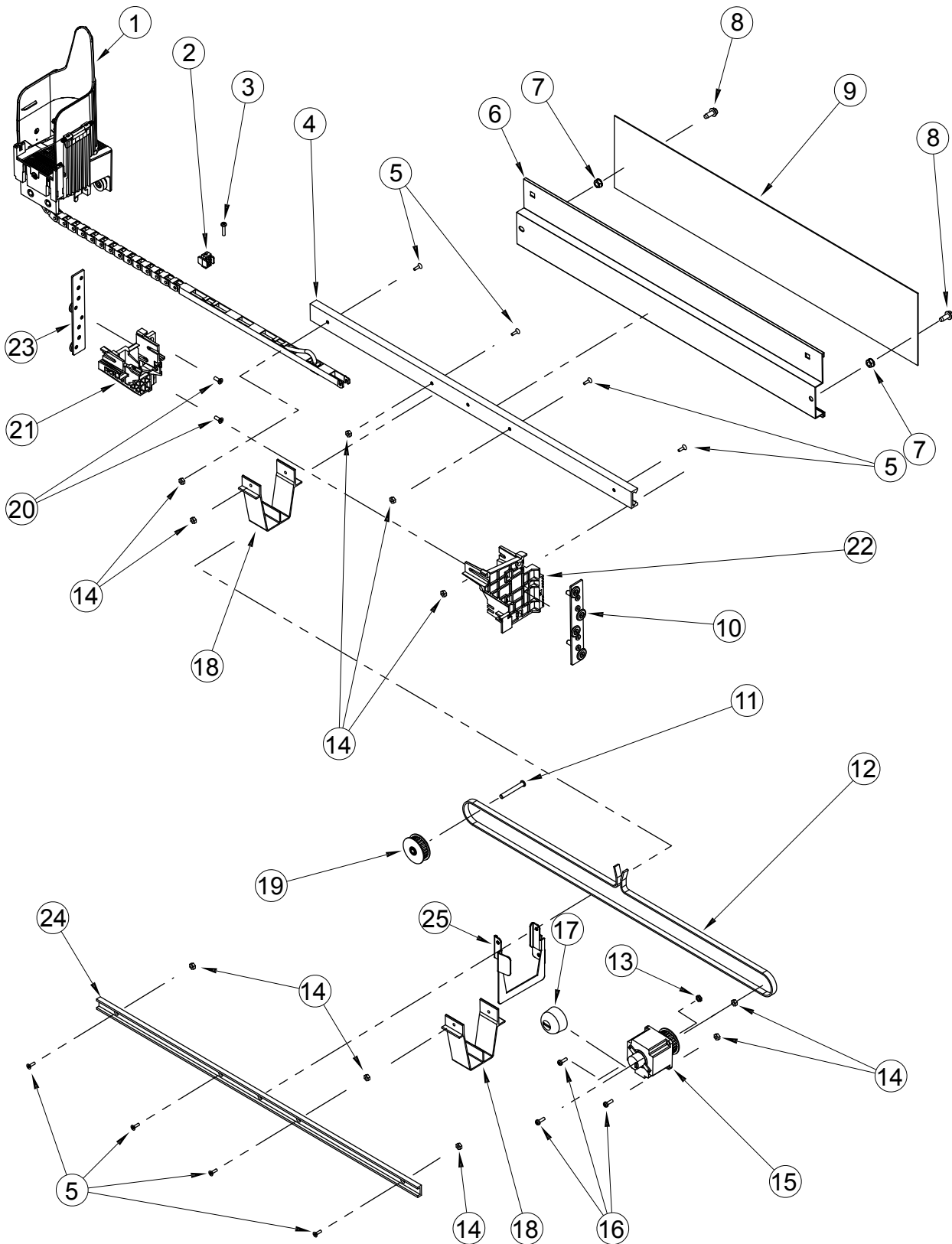

# SECTION 6: Parts Catalog

---

## Elevator Assembly 394702

ITEM NO.	DESCRIPTION	PART NUMBER
1	Product Cup Assembly.....	394701
2	X-belt Cup Clamp.....	815598
3	Screw, #8-32 x 3/4" (used to secure X-belt Cup Clamp).....	E901104
4	Vee Grooved Rail RVV NG.....	813037
5	Screw, #8-32 x 1/2" Flat Head.....	E901102
6	X-bar Sign Holder RVV NG.....	356818
7	Keps Nut, 1/4"-20.....	E905002
8	Screw, 1/4"-20 x 5/8", Black Oxide.....	901122
9	Elevator Arm Card.....	SEE NOTE
10	Traveler, Motor Mount RVV NG.....	812405
11	X-idler Shaft.....	803101
12	XL Timing Belt RVV NG.....	816128
13	Nut, Double Chamfer #8-32.....	E905040
14	Keps Nut, #8-32.....	E905001
15	X-motor Assembly RVV NG.....	356855
16	Screw, #8-32 x 1/2" Pan Head.....	901121
17	X-motor Cover RVV NG, Insulated.....	826055
18	Center Support RVV NG.....	815672
19	XL Pulley Assembly RVV NG.....	803103
20	Screw, #10-24 x 1/2" Flat Head.....	E901100
21	Carrier, Left Quick Remove RVV NG.....	815682
22	Motor Mount Quick Remove RVV NG.....	815681
23	Traveler, Left RVV NG.....	812404
24	Guide Rail RVV NG.....	813038
25	Elevator Rail Stiffener RVV NG.....	356657

**NOTE:** Please call Royal Vendors' Customer Service Department for this part number.

# SECTION 6: Parts Catalog

## Security Plate Assembly RVV Gen II, TriTeq Lock 394578

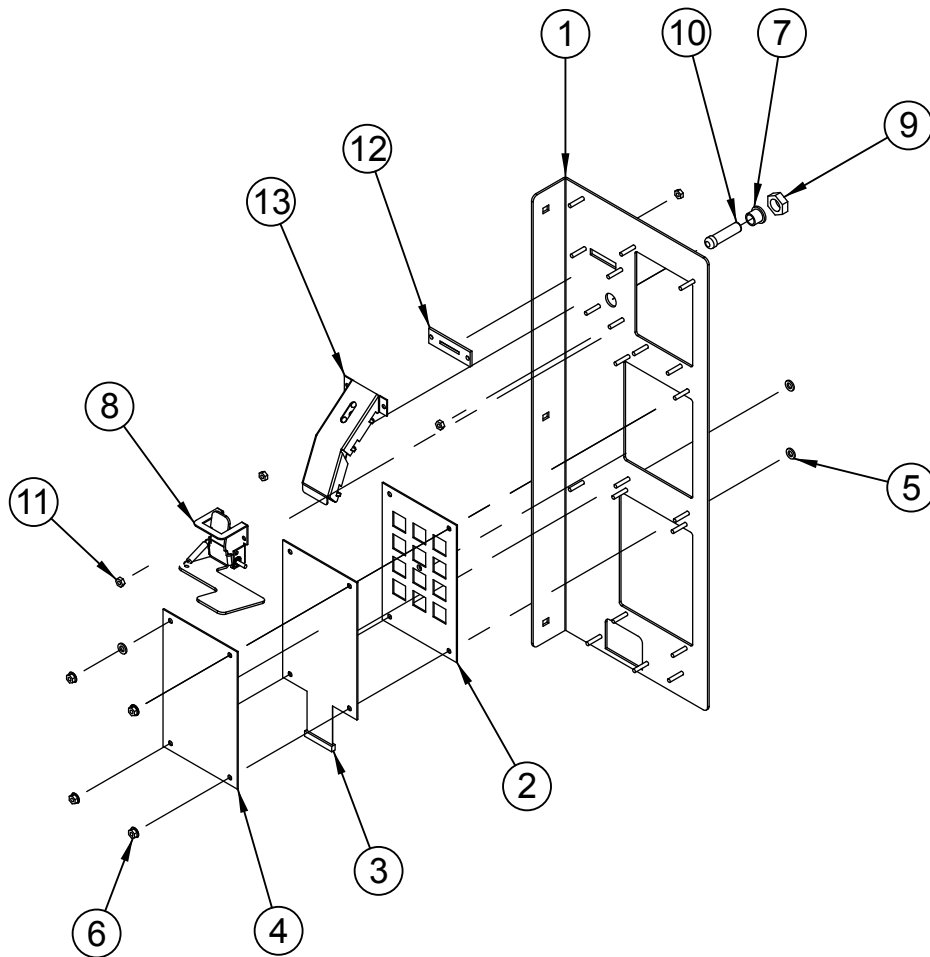

ITEM NO.	DESCRIPTION	PART NUMBER
1	Security Plate Weld Assembly, TriTeq.....	394577
2	Front Plate, Keypad .....	355556
3	Keypad.....	842643
4	Back Plate, Keypad.....	355555
5	Washer, Flat Nylon, 0.252" ID x 0.472" OD x 0.062" thick .....	E904035
6	Serrated Flange Nut, #8-32 .....	E905035
7	Bushing, Coin Return.....	803030
8	Coin Return Assembly, TriTeq.....	394598
9	Nut, Hex Jam, 9/16"-18.....	E905019
10	Button, Coin Return Lever .....	803031
11	Keys Nut, #8-32 .....	E905001
12	Coin Plate .....	354523
13	Coin Chute Assembly, TriTeq .....	394596

## SECTION 6: Parts Catalog

### Security Plate Assembly RVV Gen II, T-handle Lock 394573

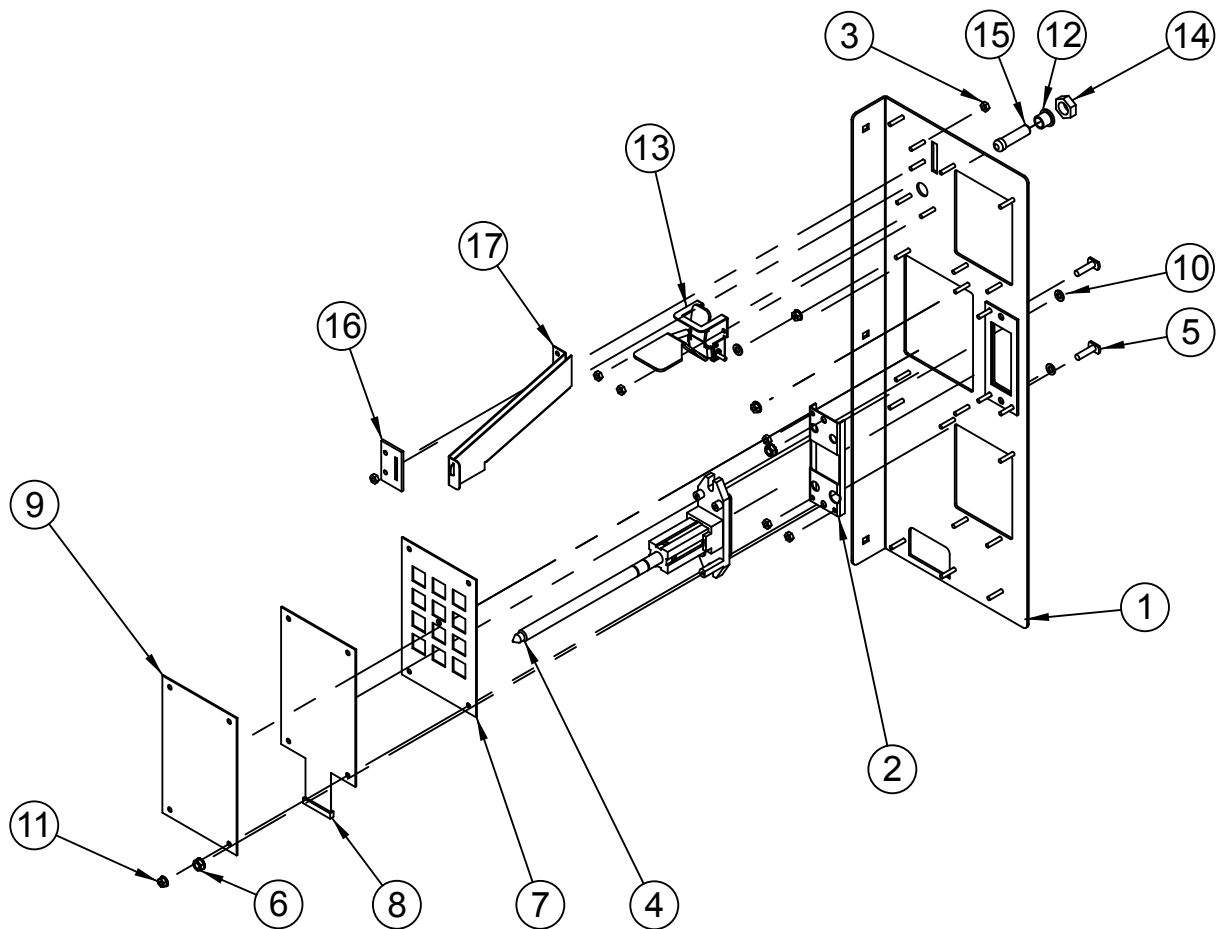

ITEM NO.	DESCRIPTION	PART NUMBER
1	Security Plate Weld Assembly, T-handle Lock .....	394572
2	T-handle Brace RVV .....	337583
3	Keps Nut, #8-32 .....	E905001
4	T-handle Assembly.....	812370
5	T-bolt, 1/4-20 x 1" .....	E901037
6	Keps Nut, 1/4"-20.....	E905002
7	Front Plate, Keypad .....	355556
8	Keypad.....	842643
9	Back Plate, Keypad.....	355555
10	Washer, Flat Nylon, 0.252" ID x 0.472" OD x 0.062" thick .....	E904035
11	Serrated Flange Nut, #8-32 .....	E905035
12	Bushing, Coin Return.....	803030
13	Coin Return Assembly, T-handle Lock .....	394539
14	Nut, Hex Jam, 9/16"-18.....	E905019
15	Button, Coin Return Lever .....	803031
16	Coin Plate RVV Gen II .....	394541
17	Coin Chute Assembly, T-handle Lock .....	394535

# SECTION 6: Parts Catalog

## RVV Gen II Door Assembly, Front

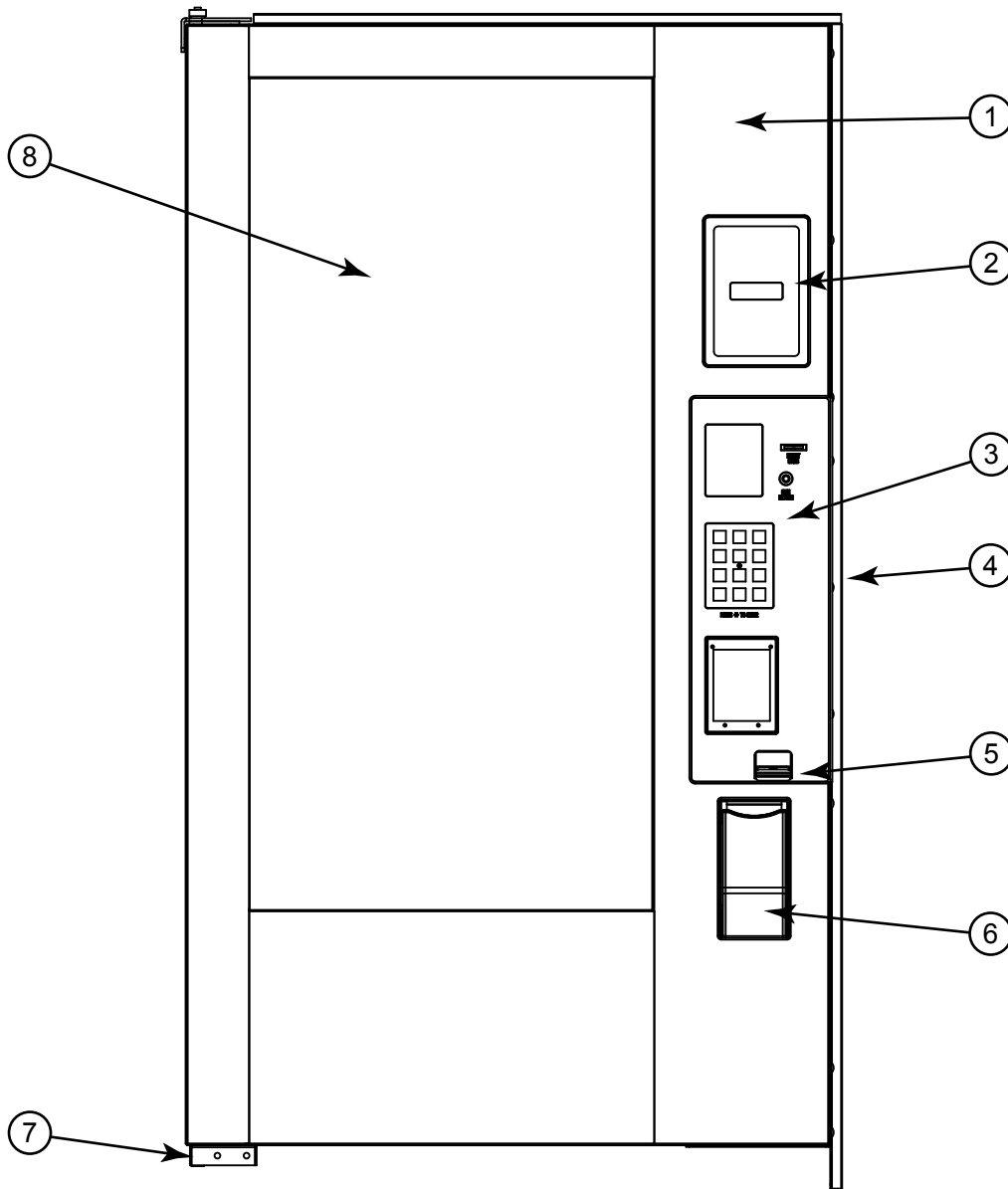

ITEM NO.	DESCRIPTION	PART NUMBER
1	Fascia .....	Contact RV Customer Service
2	Display Plate Assembly, VFD.....	394555
3	Security Plate Assembly, TriTeq Lock .....	394578
	- T-handle Lock .....	394573
4	Door Vandal Panel .....	394556
5	Enclosed Coin Cup Assembly, TriTeq Lock.....	394599
	- T-handle Lock, with Sign.....	394530
	- T-handle Lock, without Sign.....	394592
6	Port Assembly .....	394525
7	Bottom Hinge Weld Assembly.....	337599
8	Glass Panel.....	849552

# SECTION 6: Parts Catalog

## Display Plate Assembly, VFD 394555

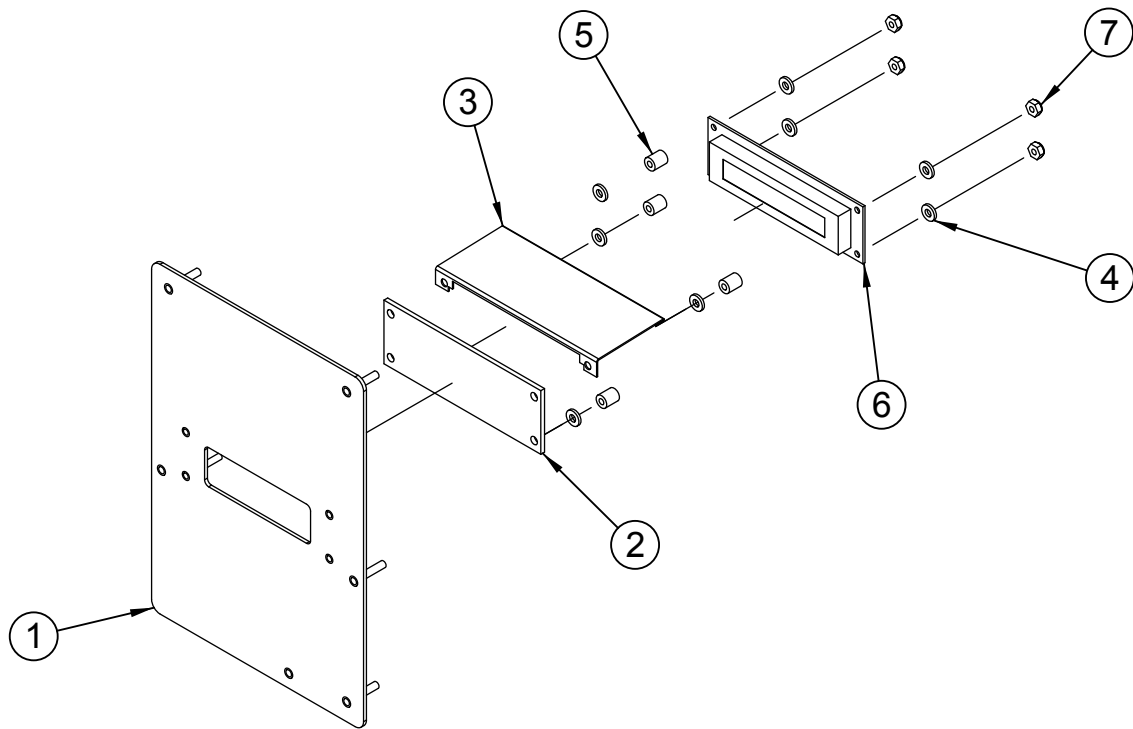

ITEM NO.	DESCRIPTION	PART NUMBER
1	Vacuum Fluorescent Display Plate .....	394913
2	Display Window RVV .....	815515
3	Display Cover, VFD.....	394912
4	Nylon Washer .....	E904029
5	Nylon Spacer .....	816184
6	Serial Display .....	836162
7	Stop Nut, Elastic, #6-32 .....	E905006

# SECTION 6: Parts Catalog

## Changer Housing Assembly, TriTeq Lock 394587

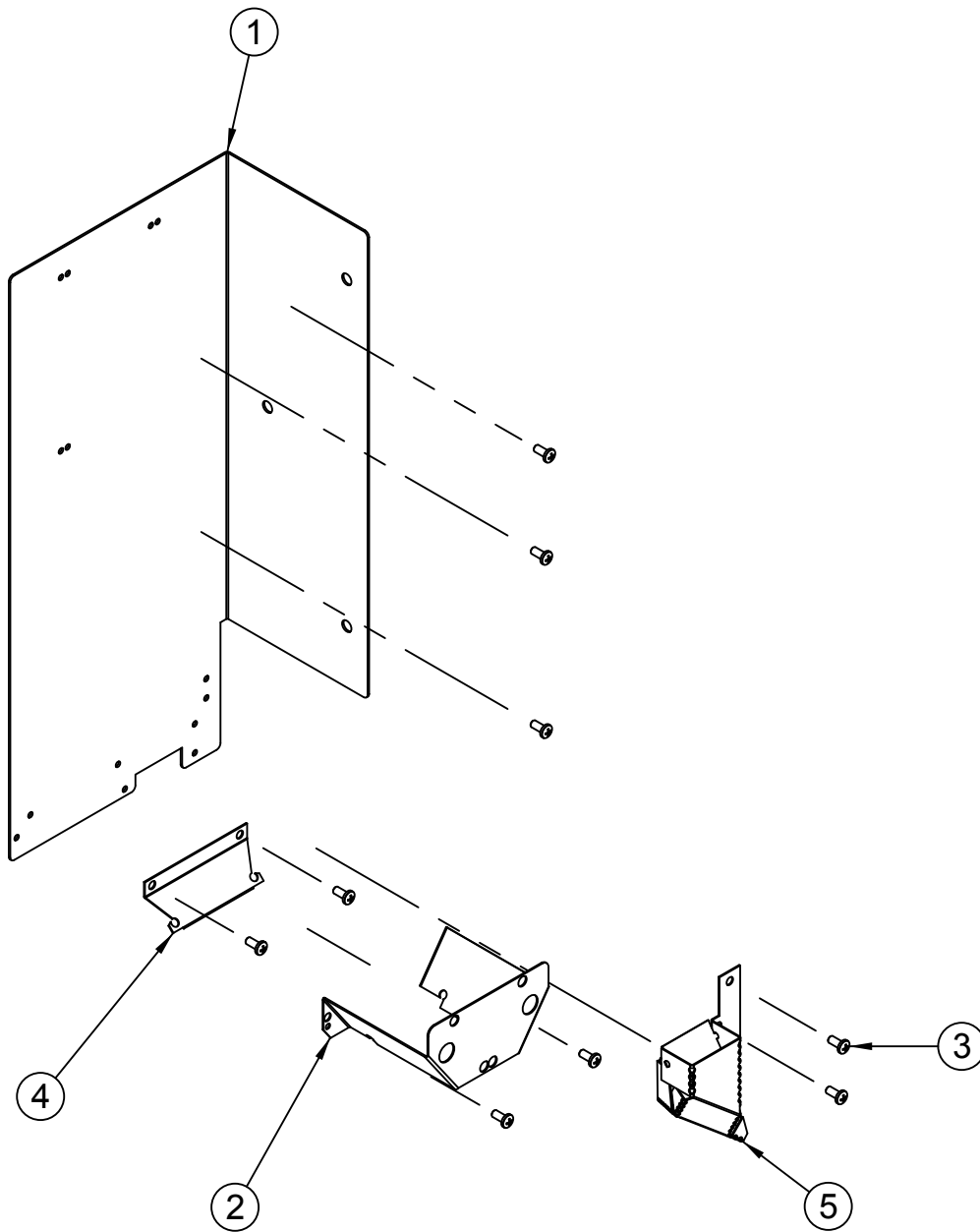

ITEM NO.	DESCRIPTION	PART NUMBER
1	Changer Bracket, TriTeq Lock.....	394586
2	Coin Hopper.....	366517
3	Screw, #8-32 x 3/8" Pan Head.....	E901011
4	Hopper Plate.....	366518
5	Lower Coin Chute Assembly, TriTeq.....	394905



## SECTION 6: Parts Catalog

### Changer Housing Assembly, T-handle Lock 394550

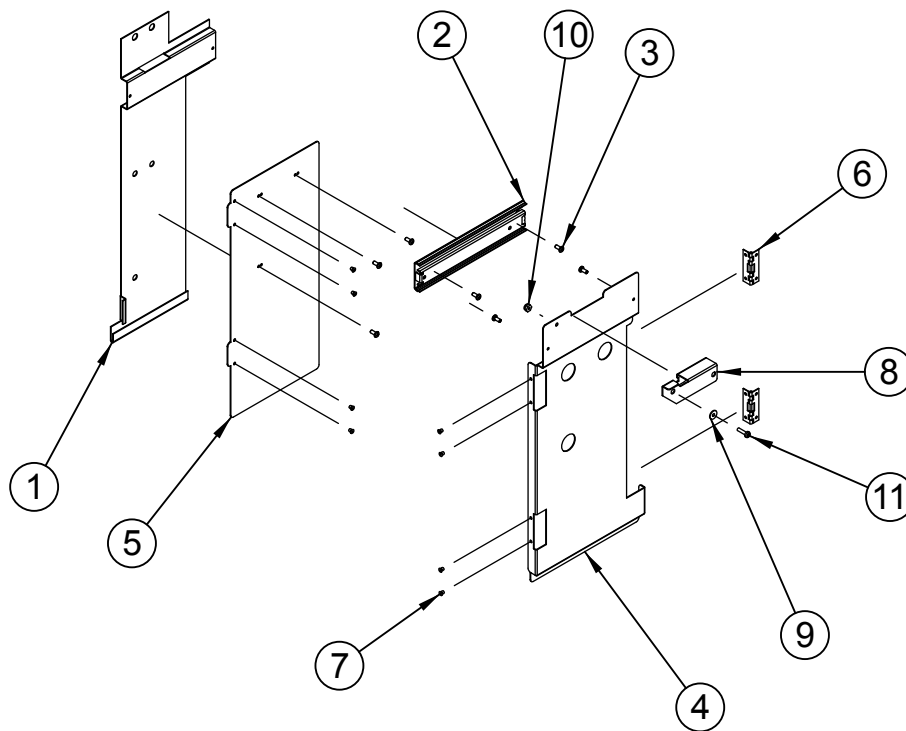

ITEM NO.	DESCRIPTION	PART NUMBER
1	Rear Slide Bracket.....	394546
2	Drawer Slide .....	812430
3	Screw, #8-32 x 3/8" Pan Head.....	E901011
4	Front Slide Bracket .....	394547
5	Changer Bracket.....	394548
6	Spring Hinge .....	912438
7	Steel Pop Rivet, 1/8" dia. x 0.256" lg .....	E908009
8	Changer Latch .....	394549
9	Lockout Bushing .....	E916150
10	Stop Nut, Elastic, #8-32 .....	E905004
11	Screw, #8-32 .....	E901103

# SECTION 6: Parts Catalog

## Port Door & Slide Assembly, TriTeq Lock 394584 (TriTeq Lock) 393545 (T-handle Lock)

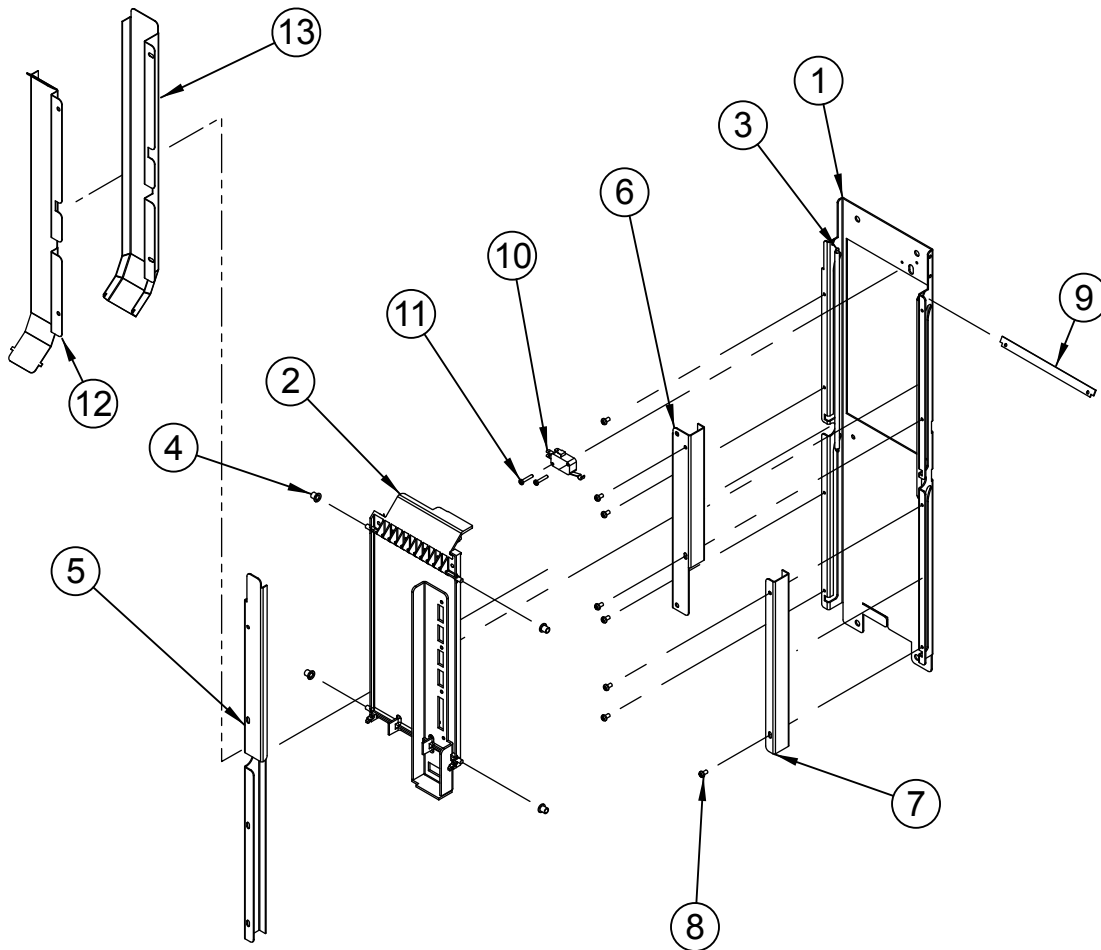

ITEM NO.	DESCRIPTION	PART NUMBER
1	Port Door Slide.....	393547
2	Port Door Assembly .....	393546
3	Extension Spring, Port Door .....	914051
4	Bushing, Delivery Door RVV .....	803092
5	Spring Cover, Left .....	393548
6	Spring Cover Top .....	366531
7	Spring Cover Bottom.....	356149
8	Screw, Tap Tite #6-32 x 1/4" .....	E901004
9	Spring Plate .....	366525
10	Switch with Actuator.....	835022
11	Sheet Metal Screw, #4 x 5/8" .....	E902009
12	Coin Box Coin Chute, Front ( <i>TriTeq only</i> ) .....	394582
13	Coin Box Coin Chute, Rear ( <i>TriTeq only</i> ).....	394583

# SECTION 6: Parts Catalog

## Port Box Assembly 394545

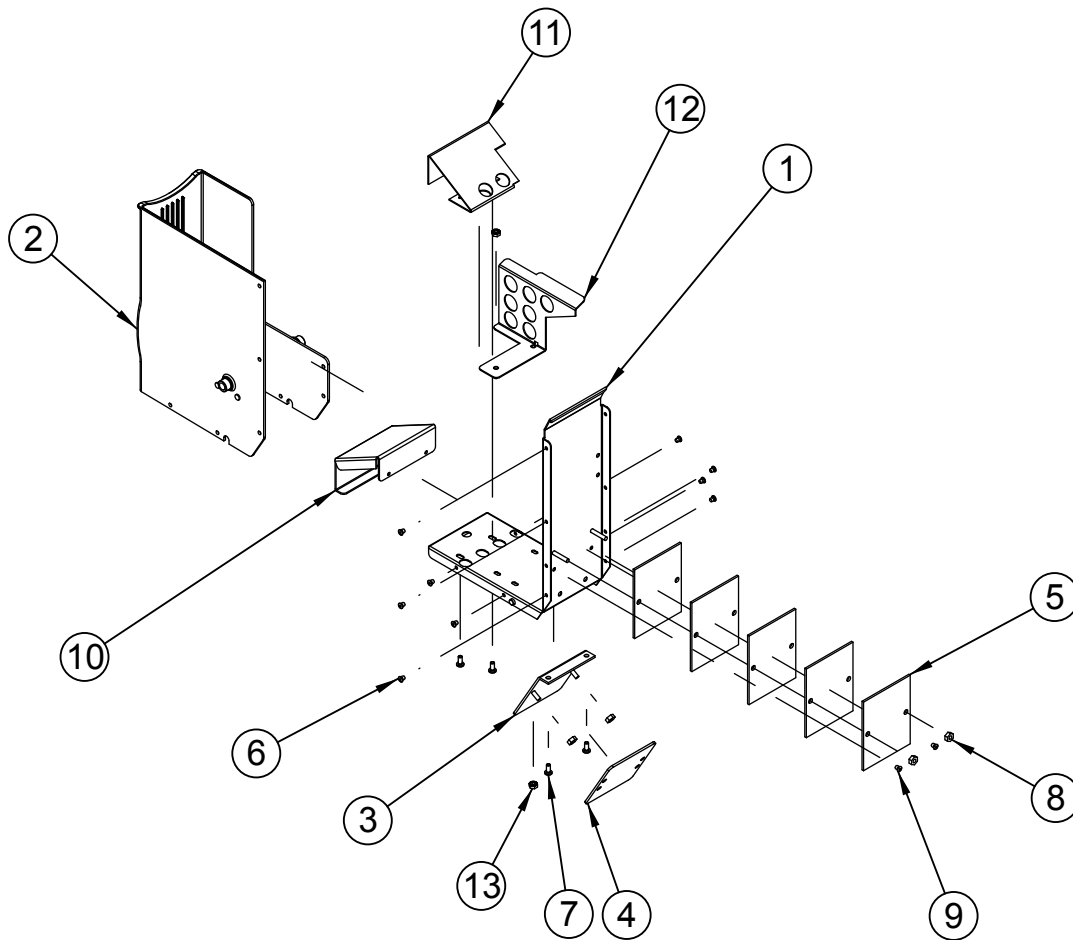

ITEM NO.	DESCRIPTION	PART NUMBER
1	Port Box Bottom with Studs .....	393542
2	Delivery Box Wrapper RVV.....	815547
3	Weight Bracket with Studs RVV.....	366589
4	Port Box Weight RVV, Smaller.....	366527
5	Port Box Weight RVV, Larger.....	337528
6	Pop Rivet, 1/8" diameter, 0.126" - 0.187" grip.....	E908007
7	Screw, #8-32 x 3/8" Pan Head.....	E901011
8	Keps Nut, #8-32.....	E905001
9	Steel Pop Rivet, 1/8" dia. x 0.256" lg .....	E908009
10	Port Bottom Filler, Rear.....	356566
11	Port Bottom Filler, Front.....	394543
12	Port Side Filler .....	356647
13	Keps Nut, #6-32.....	E905018

# SECTION 6: Parts Catalog

## Port Box Housing Assembly RVV Gen II 394519

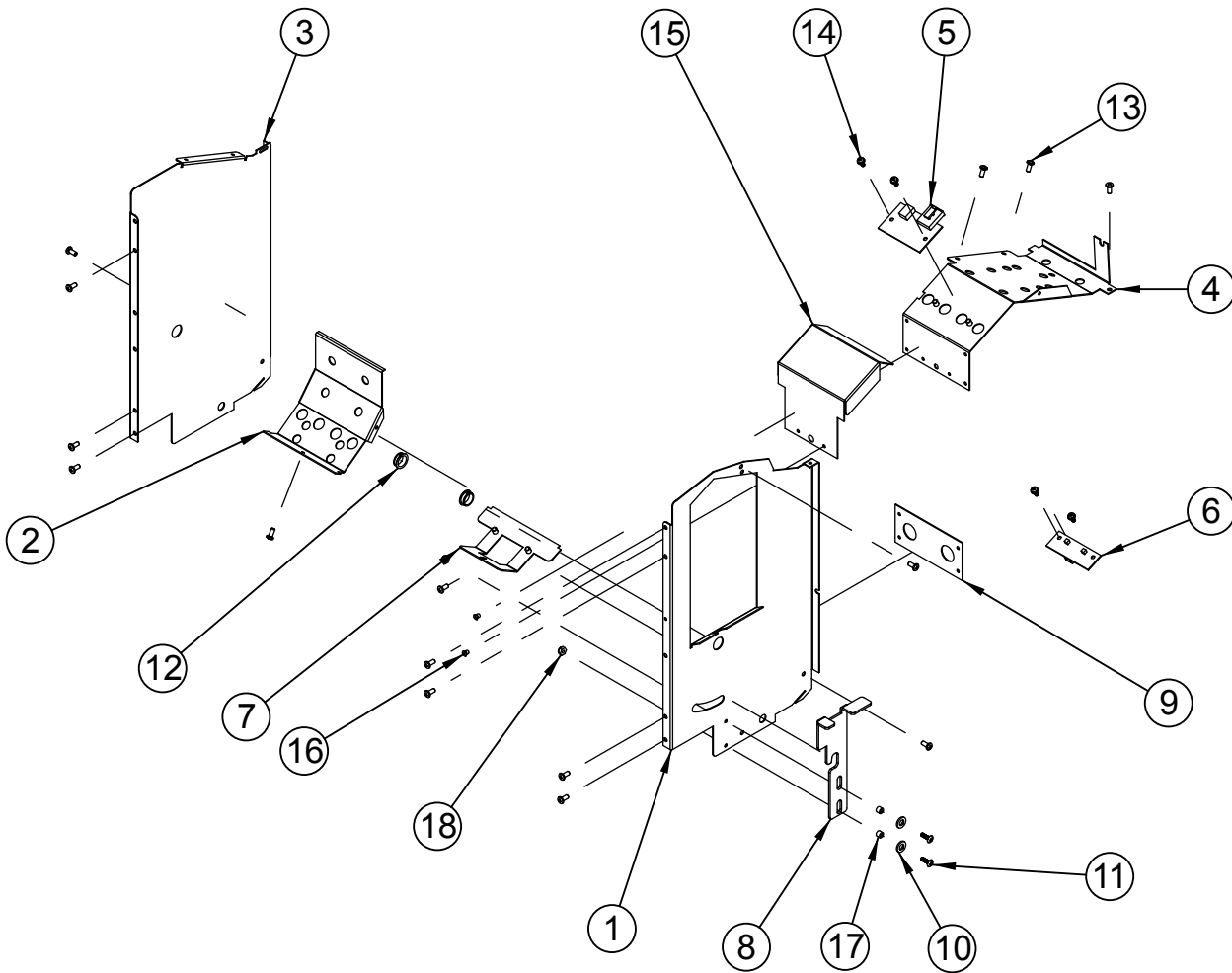

ITEM NO.	DESCRIPTION	PART NUMBER
1	Port Housing Left .....	394542
2	Port Housing Bottom.....	366505
3	Port Housing Right.....	394516
4	Port Housing Top .....	394518
5	Delivery Detector, 2 beam.....	842601
6	Delivery Emitter, 2 beam.....	842600
7	Emitter Plate with Standoffs.....	366592
8	Port Latch.....	393516
9	Port Housing Back .....	366509
10	Flat Washer.....	E904039
11	Screw, #6-32 x 1/2".....	E901108
12	Nyliner, Thomson.....	E916010
13	Screw, #8-32 x 3/8" Pan Head.....	E901011
14	Sems Screw, #6-32 x 3/8" Pan Head with Flat Washer .....	E901068
15	Optic Board Cover .....	337906
16	Rivet, Aluminum, 1/8".....	E908004
17	Spacer.....	E904038
18	Stop Nut, Elastic, #6-32 .....	E905006
•	Emitter-Detector Harness .....	842602

# SECTION 6: Parts Catalog

## Cell / Shelf Assembly RVV NG 854017 (white assembly) / 815722 (black assembly)

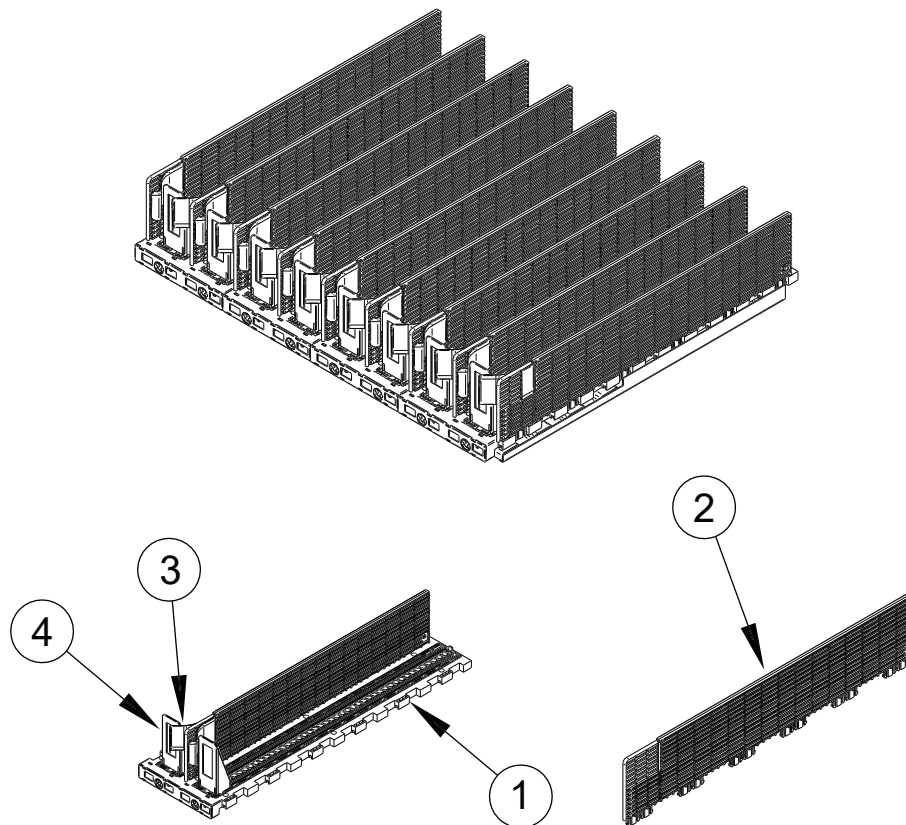

ITEM NO.	DESCRIPTION	PART NUMBER
1	Cell Assembly, Single RVV NG, White.....	854035
	- Black.....	815599
2	Sidewall, Cellbase RVV NG, White.....	854030
	- Black.....	815600
3	Package Retainer, Double, White.....	854027
	- Double, Black.....	815619
	- Single, White.....	854028
	- Single, Black.....	815628
4	Package Pusher, White.....	854031
	- Black.....	815671
•	Selection Decals (not part of assembly).....	931674
•	Magnet, Positional, X-home Sensor / Cell Base.....	803098
•	Gear, Offset.....	803121
•	Auger, White.....	854034
•	Auger, Black.....	815762
•	Drum, Output, White.....	854033
•	Drum, Output, Black.....	815763
•	Pusher Retaining Rod (rod across rear of Cell / Shelf Assembly), White.....	854032
•	Pusher Retaining Rod, Black.....	815657
•	Retaining Ring, 1/4", Stainless Steel (secures Pusher Retaining Rod).....	E906013

# SECTION 6: Parts Catalog

## RVV Gen II Cabinet

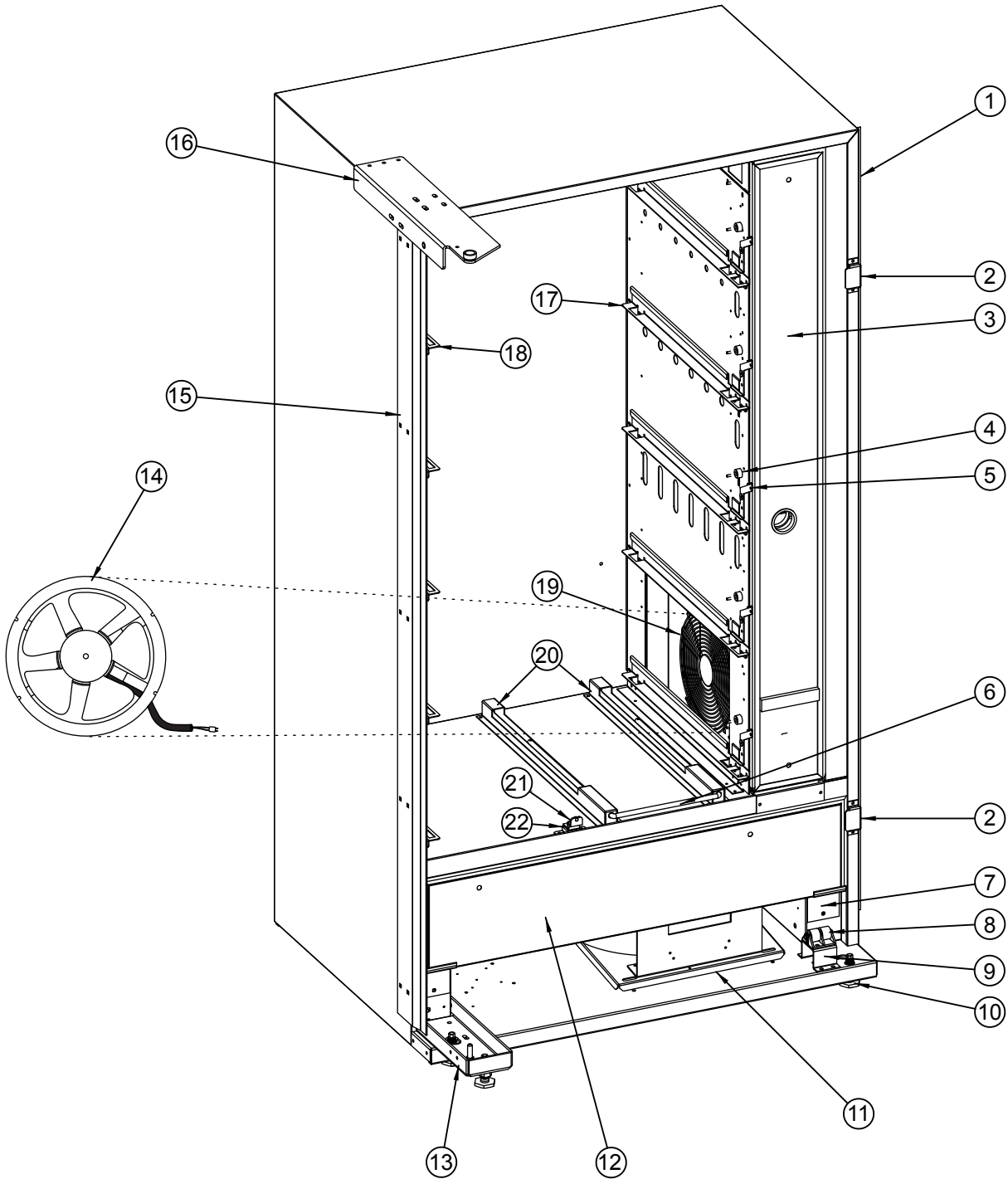

# SECTION 6: Parts Catalog

## RVV Gen II Cabinet

ITEM NO.	DESCRIPTION	PART NUMBER
1	Cabinet Vandal Panel, Right .....	356025
2	Door Switch Hat Section .....	394562
3	Inner Door Assembly, TriTeq Lock .....	394615
	- T-handle Lock .....	394610
4	Bumper .....	815493
5	Lockout Bracket .....	356703
6	Case Support .....	811067
7	Refrigeration Door Support Plate .....	337100
8	Door Lifter Assembly .....	141180
9	Roller Hat Section .....	337579
10	Levelling Leg .....	E803002
11	Refrigeration Unit .....	S337420
12	Refrigeration Door Assembly .....	394400
13	Bottom Cabinet Hinge Assembly .....	810119
14	Evaporator Fan Motor Assembly .....	231067
15	Left Vandal Panel, Cabinet .....	142022
16	Top Cabinet Hinge Assembly .....	810291
17	Shelf Rail, Right, with Lockout .....	356704
18	Shelf Rail, Left .....	356701
19	Evaporator Fan Cover .....	811052
20	Case Support Bracket .....	394003
21	X-axis Home Magnet Assembly .....	815596
22	X-axis Home Bracket .....	356808
•	Bolt, 1/4"-20 x 2" (used to secure Inner Door and Refrigeration Door) .....	E901092
•	Condensate Pan .....	815368
•	Latch Strike Assembly .....	281010
•	Programming Label .....	931662
•	Main Wiring Harness (inside cabinet bottom) .....	842424
•	Main Wiring Harness (to wall outlet) .....	842598
•	Evaporator Fan Relay Jumper (from Evap. Fan Harness to Relay) .....	842516
•	Harness, EMI Filter to Ballast / Power Supply .....	842549
•	EMI Filter .....	842061
•	Relay .....	836290
•	Drain Spout (black) .....	815134
•	Drain Tube (to condensate pan) .....	925048
•	Screw, 1/4"-20 x 1" (used to mount Evaporator Fan Cover) .....	901003
•	Spacer, 0.50" (used when mounting Evaporator Fan Cover) .....	915181
•	Spring, Main Door Harness to Cabinet .....	E914031

# SECTION 6: Parts Catalog

## Evaporator Section

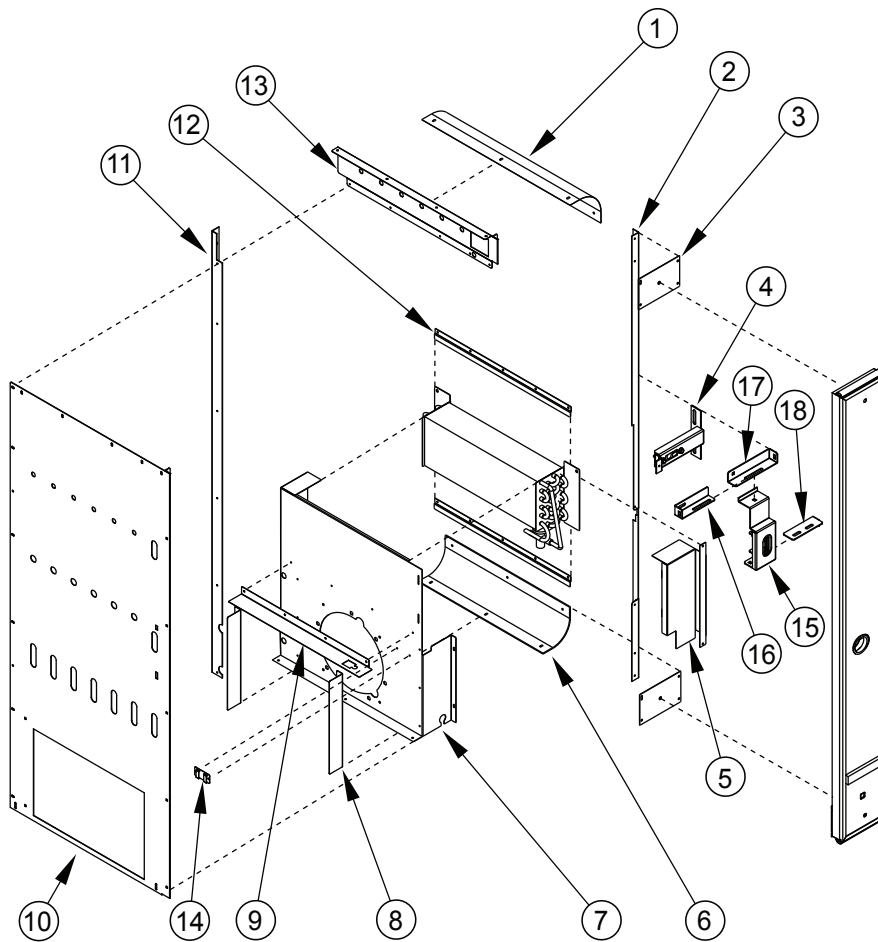

ITEM NO.	DESCRIPTION	PART NUMBER
1	Top Air Guide .....	337007
2	Inner Door Channel, Right .....	337025
3	Inner Door Channel, Top / Bottom .....	337020
4	Latch Strike Assembly, <i>T-handle lock only</i> .....	394006
5	Evaporator Cover .....	393000
6	Bottom Air Guide .....	337008
7	Evaporator Fan Housing .....	393006
8	Fanport, Side .....	356004
9	Fanport, Top .....	393008
10	Baffle Wall .....	356041
11	Inner Wall Bracket .....	356006
12	Evaporator Slide .....	393007
13	Air Duct, Top .....	356015
14	Sensor Bracket .....	810085
15	Strike Assembly, <i>TriTeq only</i> .....	812364
	- Strike Bracket, <i>TriTeq only</i> .....	394001
16	Adjustable Lock Bracket, <i>TriTeq only</i> .....	356005
17	Lock Bracket, <i>TriTeq only</i> .....	356001
18	Strike Bracket Support, <i>TriTeq only</i> .....	394002



# SECTION 6: Parts Catalog

## TriTeq Lock Assembly

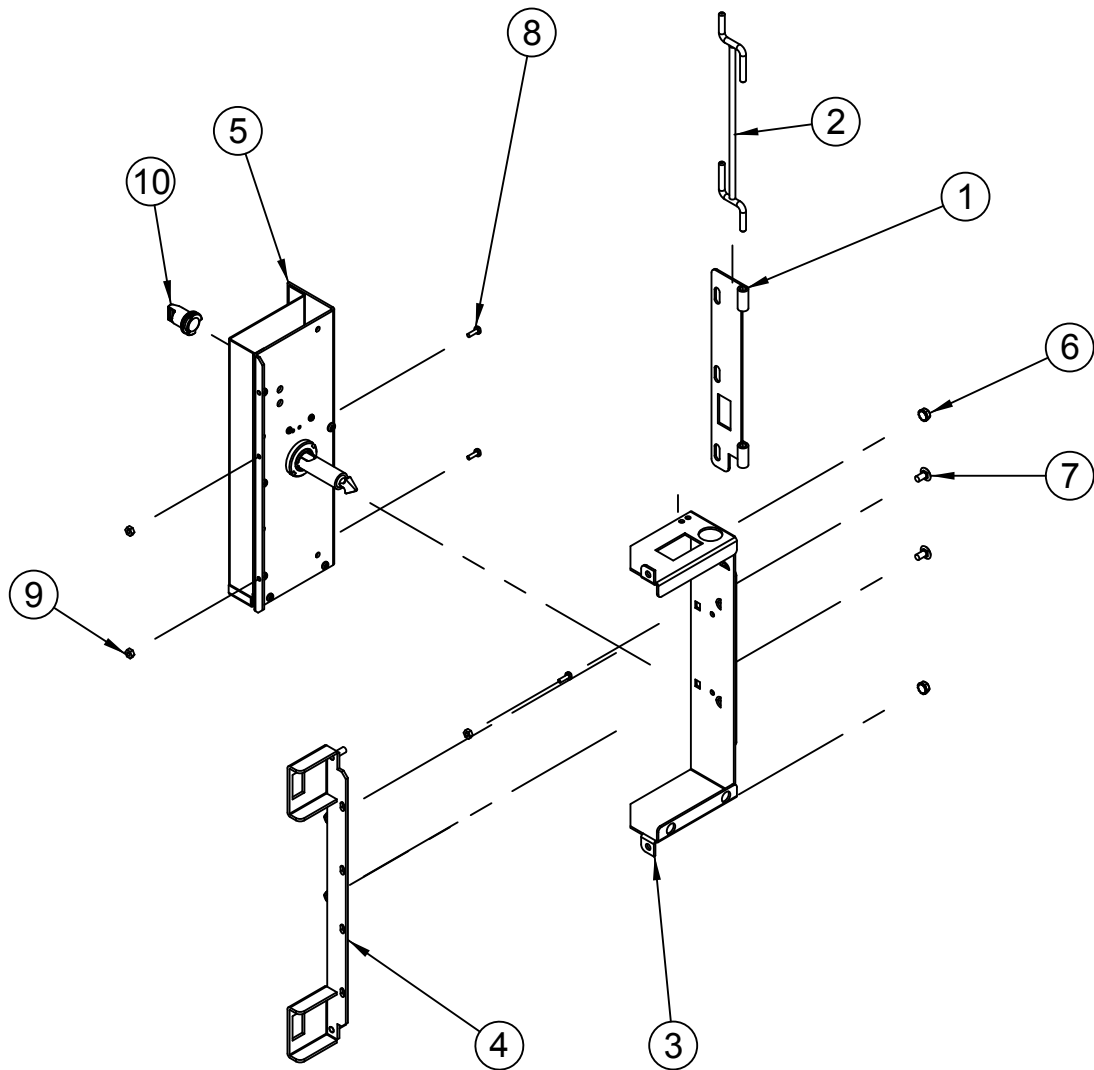

ITEM NO.	DESCRIPTION	PART NUMBER
1	Hinge Leaf, Door Side.....	356557
2	Hinge Pin .....	811068
3	Lock Housing Assembly.....	356554
4	Strike Plate Assembly .....	394922
5	TriTeq Lock .....	812363
6	Keps Nut, 1/4"-20.....	E905002
7	Carriage Bolt, 1/4"-20 x 1/2".....	E901007
8	Sems Screw, #8-32 x 1/2".....	E901002
9	Keps Nut, #8-32.....	E905001
10	Light Pipe.....	812433

# SECTION 6: Parts Catalog

---

# Programming Flowchart

## ROYAL VISION VENDER Next Generation 5-Button Programming Flowchart

### Internal (Service) Menu

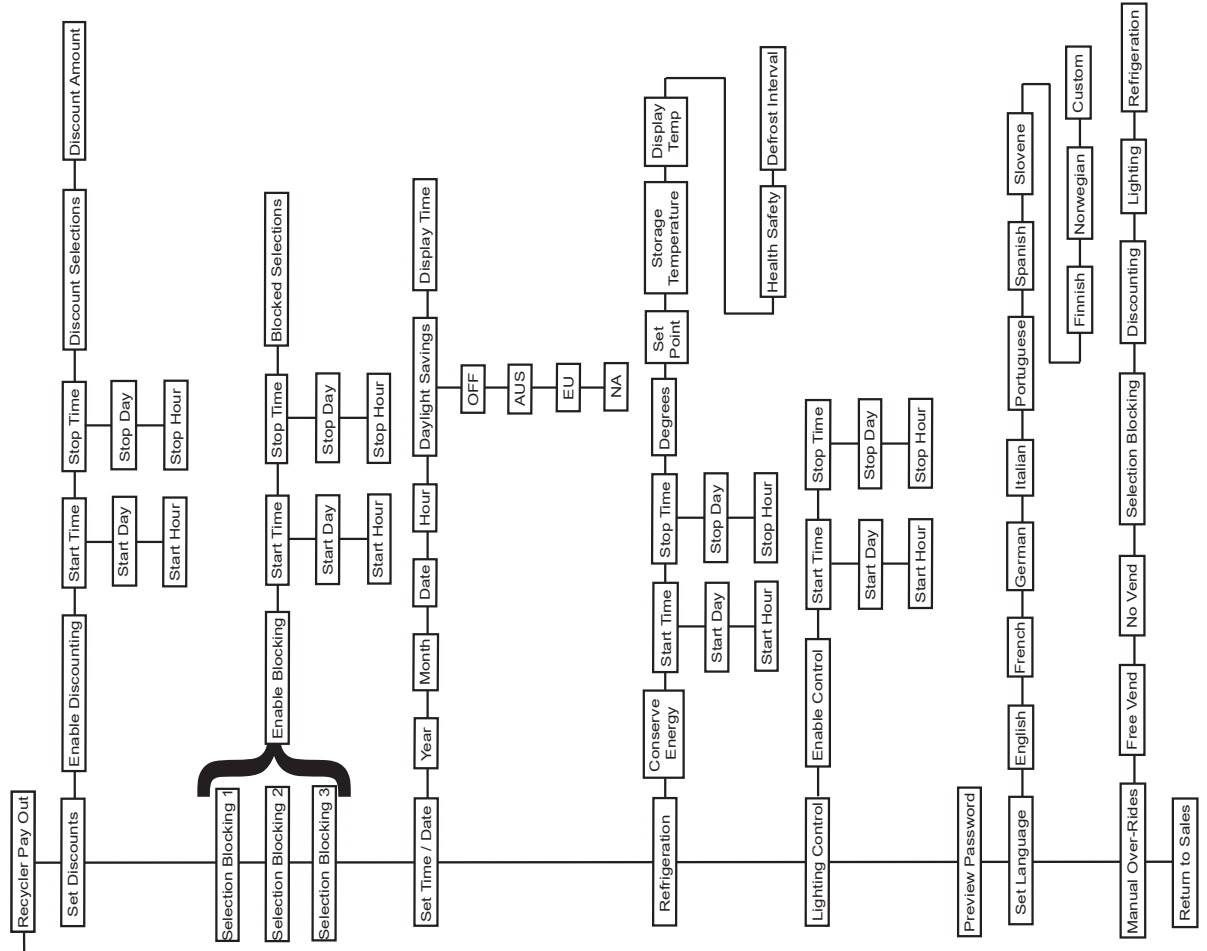
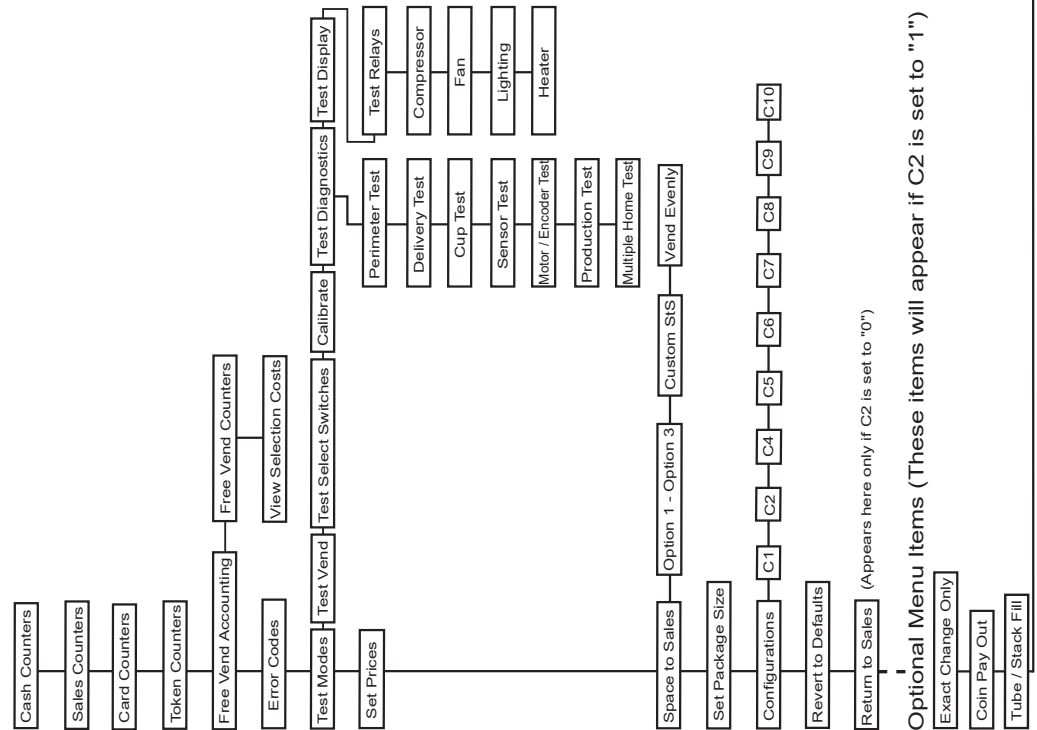

Rev VI  
Apr 2017

# Wiring Schematic

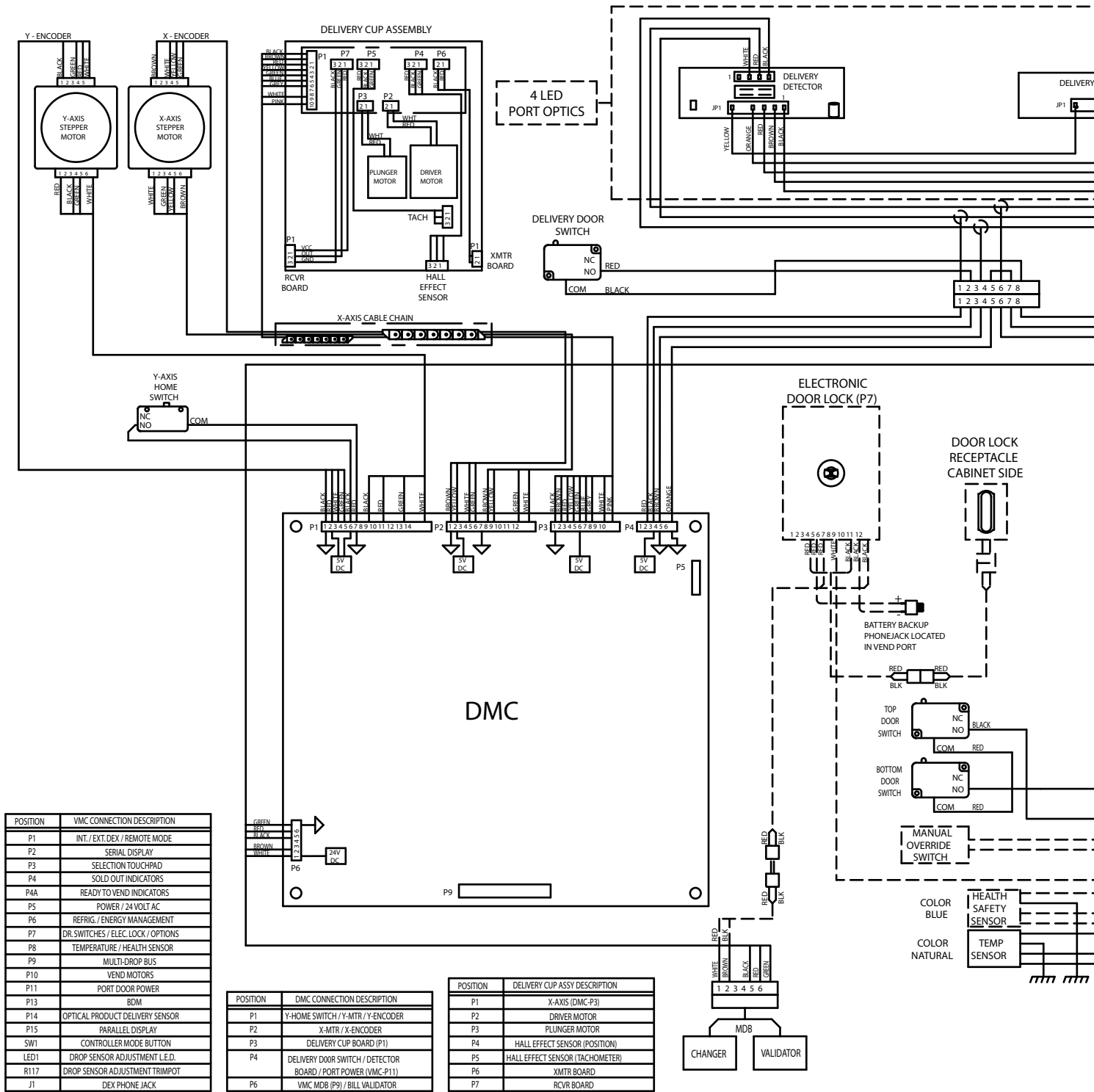

# Wiring Schematic

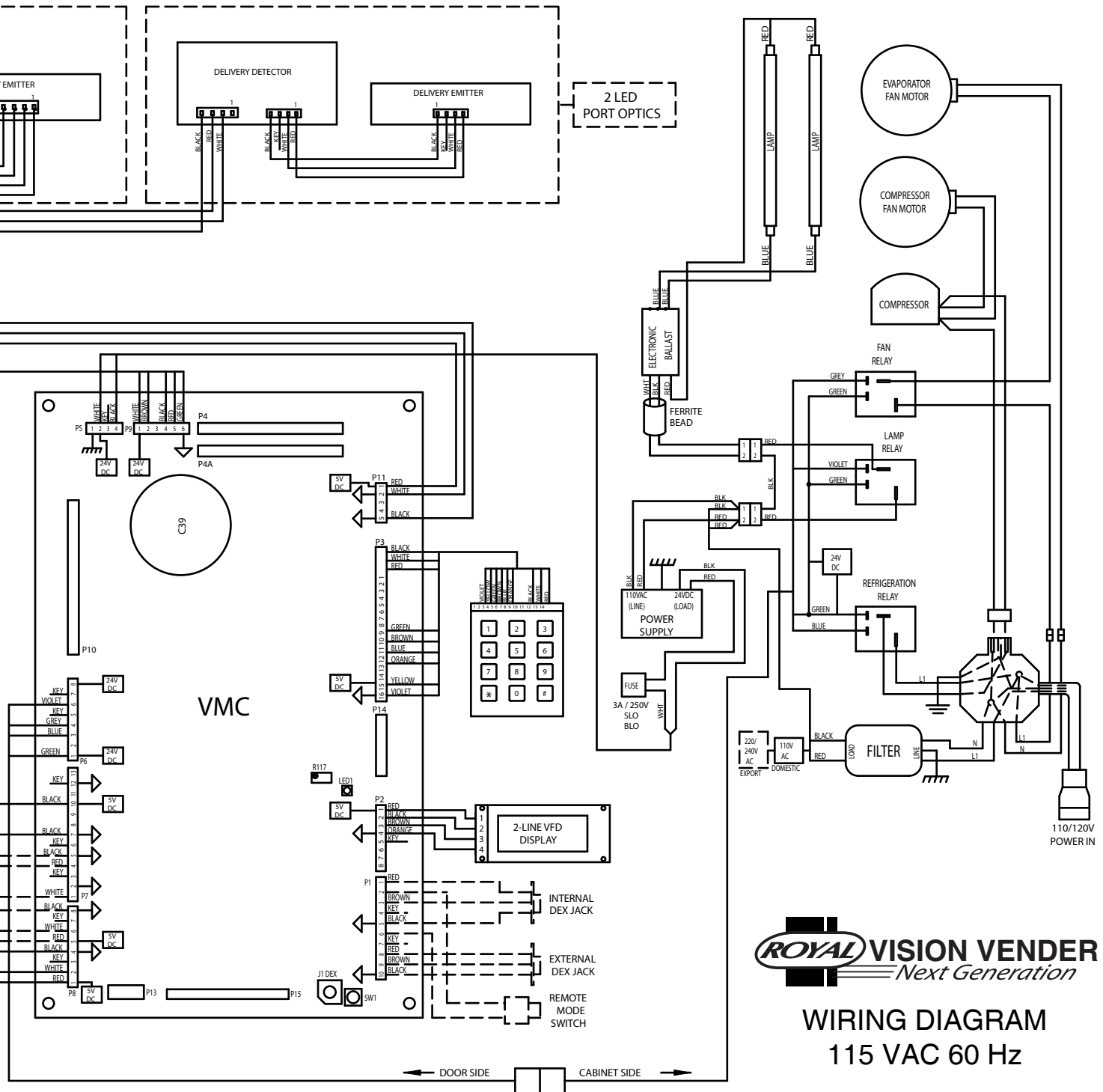





## CREDIT AND REPLACEMENT POLICY

Credits or replacements will be issued on warranty items if the proper procedures are followed:

1. ROYAL VENDORS will pay shipping charges on all parts covered under this warranty when transportation has been made the most economical way. (Example: Within the continental USA, regular ground UPS). An A.R.S. (Authorized Return Service) sticker will be sent with all warranty parts. This method of shipping is preferred for returning parts to Royal.
2. Credits will only be issued to warranty parts that have been ordered in advance, not for parts ordered as stock. (NO EXCEPTIONS)
3. When ordering warranty parts in advance, please have the full vender, refrigeration unit, and / or control board serial numbers.
4. A copy of the Packing Slip, the correct serial number and complete Return Material Tag (provided with part) are required for returning parts. Please fill out the Return Material Tag completely, keeping the white copy for your records and returning the yellow tag with the attached part. Make sure to fill in the company name, address, telephone number, serial number, and model number, along with a brief explanation of the problem.
5. If the item returned is not under warranty, it will be returned at your expense along with a US\$10.00 handling fee or it will be scrapped.
6. All warranty parts should be properly wrapped and packed securely to avoid further damage. Parts that are returned from the field and have been tapped into, tampered with, not packaged properly, or have had the serial plate or label removed, will void the warranty.
7. If parts are not returned within 15 working days, the invoice will be due in full.



Royal Vendors' Publication  
833105 Rev. 01  
April 2017



*Printed in the United States of America*